

High Pressure Horizontal or Vertical Shaft Multistage Centrifugal Pumps

KMU, OMK & OMKV, KME & KMEV Series

Operating Manual 2024

MDK BK172024



masdaf.com



EC DECLARATION OF CONFORMITY

AT UYGUNLUK BEYANI

Manufacturer / İmalatçı : MAS DAF MAKİNA SANAYİ A.Ş.

Address / Adres : Orta Mah. Atayolu Cad. No: 16 Tuzla - İSTANBUL / TÜRKİYE
Organize Sanayi Bölgesi, Beyköy Beldesi, İstiklal OSB 1 Mah. 5. Cad. Dış Kapı No:7
Merkez/ DÜZCE

Name and address of the person authorised to compile the technical file : Vahdettin YIRTMACI
Orta Mah. Atayolu Cad. No: 16
Tuzla - İSTANBUL / TÜRKİYE
Teknik Dosyayı Derleyen Yetkili Kişi ve Adresi

The undersigned Company certifies under its sole responsibility that the item of equipment specified below satisfies the requirements of the mainly Machinery Directive 2006/42/EC which is apply to it.

The item of equipment identified below has been subject to internal manufacturing checks with monitoring of the final assessment by MAS DAF MAKİNA SANAYİ A.Ş.

Aşağıda tanımlanmış olan ürünler için Makine Emniyeti yönetmeliği 2006 / 42 / AT' nin uygulanabilen gerekliliklerinin yerine getirildiğini ve sorumluluğun alınmış olduğunu beyan ederiz.

Aşağıda tanımlanan ürünler iç üretim kontrollerine bağlı olarak MAS DAF MAKİNA SANAYİ A.Ş. tarafından kontrol edilmiştir.

Equipment / Ürün : High Pressure Vertical and Horizontal Shaft Multistage Centrifugal Pumps
Yüksek Basıncılı Dikey veya Yatay Milli Çok Kademeli Santrifuj Pompalar
Seri / Model-Tip : KMU, OMK & OMKV, KME & KMEV Series
KMU, OMK & OMKV, KME & KMEV Serileri

For pumps supplied with drivers/ Elektrikli Pompa Üniteleri

Related Directives / Yönetmelikler

2006/42/EC Machinery Directive / 2006/42/AT Makine Emniyeti Yönetmeliği

2014/35/EU Low Voltage Directive / 2014/35/AB Alçak Gerilim Yönetmeliği

2014/30/EU Electromagnetic Compatibility Directive / 2014/30/AB Elektromanyetik Uyumluluk Yönetmeliği

EUP 2009/ 125 /EC Electric Used Products Directive/ Elektrik Kullanan Ekipmanlar Direktifi (EUP)

2009/125/EC European Ecodesign Directive, Regulation No: 547/2012 Ecodesign Requirements for Water Pumps / Avrupa Ekotasarım Direktifi. (SGM-2015/44) 547/2012 No' lu Su Pompalarında Ekotasarım Regülasyonu

Regulations applied acc. to harmonize standards / Uygulanan Uyumlaştırılmış Standartlar
TS EN ISO 12100:2010, TS EN 809+A1, TS EN 60204-1:2018.

We hereby declare that this equipment is intended to be incorporated into, or assembled with other machinery to constitute relevant machinery to comply with essential health and safety requirements of Directive The machinery covered by this declaration must not be put into service until the relevant machinery into which it is to be incorporated has been declared in conformity with provisions of the directive.

Ekipman, uygun bir makina oluşturmak amacıyla diğer ekipmanlar ile birleştirilirken ya da monte edilirken gerekli sağlık ve güvenlik yönetmeliklerine uyulması gerekmektedir.

Bu bildiri kapsamında yönetmelikte belirtilen bütün hükümler yerine getirilmeden makinanın devreye alınmaması gerekmektedir.

Place and date of issue / Yer ve Tarih : İstanbul, 01.08.2019

Name and position of authorized person : Vahdettin YIRTMACI
Yetkili Kişinin Adı ve Görevi : Genel Müdür / Genel Müdür

Signature of authorized person
Yetkili Kişinin İmzası



TABLE OF CONTENTS	Page No
Introduction	06
1. Important Safety Precautions	07
2. General	07
2.1. Definition Of Pump And Usage Areas	07
2.2. Performance Information	08
2.3. Warranty Conditions	08
2.4. Test	08
2.5. Pressure Limit	08
3. Safe Operating Conditions	08
3.1. Training Of Personnel	09
3.2. Hazardous Conditions That May Occur When One Does Not Comply With The Safety Instructions	09
3.3. Safety Measures For Operator	09
3.4. Safety Measures For Maintenance And Installation	09
3.5. Spare Parts Replacement	09
4. Technical Information	09
4.1. Design	09
4.2. Construction Of Pump Group	11
5. Transport And Storage	12
5.1. Transport	12
5.2. Storage	13
6. Assembly / Installation	13
6.1. Installation	13
6.2. Type Of Connection	13
6.3. Piping	13
6.4. Motor Connection	15
6.5. Coupling Alignment	16





7. Commissioning, Start Up And Operating	18
7.1. Preparations Before Start Up	18
7.2. Checking The Direction Of Rotation	18
7.3. Start Up Procedure	19
7.4. Shut Down Procedure	19
8. Maintenance	20
8.1. The Checks During The Operation	20
8.2. Service	21
8.3. Spare Parts	22
9. Noise Level And Vibration	22
9.1. Expected Noise Values	22
10. Disassembly, Repair And Reassembly	23
10.1. Disassembly	23
10.2. Reassembly	23
10.3. Safety Precautions For Maintenance And Assembly	24
10.4. Spare Part Replacement	24
11. Possible Failures, Causes And Solutions	25
12. Tightening Torques	30
13. Forces And Moments At The Pump Flanges	31
14. Sample Plumping System	32
15. Sectional Drawings And Part Lists	34
16. Exploded Views And Part Lists	48





INTRODUCTION



- This manual contains instructions for the installation, operation and maintenance of the KMU, OMK & OMKV, KME & KMEV type horizontal and vertical, high pressure, multistage centrifugal pumps of **MASDAF MAKINA SANAYI A.Ş.**
- Please read carefully this manual and apply all the instructions to operate pumps without problems. Pumps shall be used for their intended duties. In this manual, there are information on operating conditions, installation, starting-up, settings and main controls of pumps.
- These operating and maintenance instructions contain **MASDAF MAKINA SANAYI A.Ş.**'s suggestions. The special operating and maintenance information of the plumbing that a pump is fitted to is not considered in these instructions. This information must be given by the plumbing constructors only.
- **Please refer to instructions of plumbing constructors.**
- Please pay attention to the warnings in this manual and ensure that it is read before the installation-start up process. **MASDAF MAKINA SANAYI A.Ş.** is not responsible for the accidents resulting from negligence.
- If you cannot find an answer to your questions in this manual, it is suggested that you contact **MASDAF MAKINA SANAYI A.Ş.** Please inform us about the rated value and especially the serial number of the pump when you get in contact for help.
- The safety instructions in this manual cover the current national accident protection regulations. Beside all of these, an operation, work and safety measure imposed by the costumer has to be applied.

The Signs Used in This Operation Manual



Read the instructions carefully in this operating manual and keep it for your future reference.



Warning sign against the electrical risks



Sign for the operator's safety





1. IMPORTANT SAFETY PRECAUTIONS

In order to minimize the accidents during the mounting and putting into service of the pump, the following rules have to be applied:

1. Do not work without taking safety measures relevant to equipment. Cable, mask and safety band must be used when necessary.
2. Be sure there is adequate amount of oxygen and there is no toxic gaseous around
3. Before using welding or any electrical equipment make sure that there is no risk of explosion.
4. Check the cleanliness of the area to take care of your help. (Dust smoke, etc.)
5. Do keep in mind that there is a risk of having accidents related to electricity
6. Do not lift the pump before you check the transport equipment.
7. Be sure you have a by-pass line
8. Use helmet, eye glasses and protective shoes for your safety
9. Place a protective barrier around the pump within the necessary safety area
10. Dust, liquids and gaseous that may cause overheating, short circuit, corrosion and fire must be kept away from the pump unit.
11. By checking the noise level of the pump unit, necessary measures to avoid noisy operation of the pump that can have harmful effects on the personnel and environment.
12. Be careful about the direction of transport and storage.
13. Cover appropriately the moving parts to avoid possible injury of the personnel. Mount the coupling guard and belting before starting-up the pump
14. All the electrical and electronic applications must be performed by authorized person conforming EN60204-1 and/or domestic instructions.
15. Protect the electrical equipment and motor against overloading
16. If flammable and explosive liquids are pumped, ground connection of electricity should be carried out properly
17. Do not expose the pump unit to sudden temperature variations

18. All personnel who work with the waste water system need to be vaccinated in case of contagious diseases.
19. If the pump contains hazardous liquids, one must use protective helmet against the risk of splatter. One also must accumulate the liquid in a proper container against any risk of leakage.

All Other Health and Safety Rules, Laws and Regulations Must Be Applied

2. GENERAL

2.1. Definition of Pump and Usage Areas

KMU, OMK, KME series pumps are horizontal shaft high pressure multistage centrifugal pumps while OMKV and KMEV are vertical shaft high pressure multistage centrifugal pumps. They are used in:

For pumping of clear and slightly contaminated liquids,

- Drinking water systems
- Booster sets in high rise buildings and industry
- Water treatment plants
- Fire extinguishing systems
- Sanitary and cleaning installations
- Industrial applications
- Water distribution systems
- Shipbuilding, Mining, Power Stations
- Irrigation plants

They shall be used to pressurize liquids which are clean or mildly impure, non abrasive, and not containing large solid particles or fiber.

CAUTION

Please contact MASDAF MAKINA SANAYI A.Ş. for liquids that have different chemical and physical specifications..





Product Information as per Regulation No. 547/2012 (for Water Pumps with a Maximum Shaft Power of 150 kW) Implementing "Ecodesign" Directive 2009/125/EC.

'Vertical multistage water pump' (MSV) means a glanded multi stage ($i > 1$) rotodynamic water pump in which the impellers are assembled on a vertical rotating shaft, which is designed for pressures up to 25 bar, with a nominal speed of 2900 rpm and a maximum flow of 100 m³/h.

Minimum Efficiency Index for MAS OMKV Pump Series is shown on the pump label.

MEI values of MAS OMKV Pump Series are shown on the pump characteristic curves.

Minimum Efficiency Index for MAS OMKV Pump Series: Minimum 0.4. ($MEI \geq 0.4$)

Efficiency values of the pump characteristic curves, which are cut diameter, are expressed in %.

OMKV Series water pumps, the pump efficiency can be achieved more than fix speed in case of variable speed control.

More information about the Ecodesign can be reached at www.europump.org

2.2. Performance Information

Actual performance of the pump can be obtained from the order page and/or from the test report. This information is given on the pump label. The performance curves given in the catalog are valid for water whose density and viscosity are $\rho = 1 \text{ kg/dm}^3$ and $\nu = 1 \text{ cst.}$ respectively. For those liquids whose densities and viscosities are different from those of water, please consult with **MASDAF MAKINA SANAYI A.Ş.** since the performance curves vary with density and viscosity.

CAUTION

Do not operate the pump with a motor that has a different power except for the given catalog and label values.



The pump is not to be operated at off-design point given in the order and supplied from the firm. It is necessary to ensure that the instructions are obeyed for the safe running of the pump.

2.3. Warranty Conditions

The entire products in our selling program are warranted by **MASDAF MAKINA SANAYI A.Ş.**

The warranty conditions will only be valid when all the instructions about installation and start-up operations of the pump unit are taken into account.

2.4. Test

Pump performance values are valid under our factory test conditions.

2.5. Pressure Limit



Pressure at the discharge flange must not exceed operating pressure. A special order is necessary for applications with higher pressures.

3. SAFE OPERATING CONDITIONS

This manual contains main safety instructions for the installation, operation and maintenance. It must be read by the personnel who are responsible for installation and operation. This manual should always be kept near the installation location. It is important to comply with safety precautions stated in page 1 along with the general safety instructions as well as preventive measures repeated in other sections of this manual.



3.1. Training of Personnel

Installation, operation and maintenance personnel must have necessary knowledge in order to accomplish the given job. The responsibility, adequacies and controlling duties of such personnel must be determined by the customer. It has to be certain that these personnel comprehend totally the content of the operating manual. If the personnel do not have enough knowledge, required training must be given by the customer. If training support is needed by the customer, it will be provided by the manufacturer/seller.

CAUTION

Untrained personnel and unwillingness to comply with safety instructions may be risky for both machine and environment. MASDAF MAKINA SANAYI A.Ş. is not responsible for this kind of damages.

3.2. Hazardous Conditions That May Occur When One does not Comply With the Safety Instructions

Incompliance with safety regulations may put the personnel, the environment and the machine in danger and thus may cause damages. Incompliance with safety regulations may give rise to situations listed below.

Important operational functions of the factory may stop.

**Maintenance may get difficult.
One may get injured by electrical, mechanical or chemical hazards.**

3.3. Safety Measures for Operator

Dangerous, hot or cold components in the pump area must be covered so that one cannot touch them.

Moving components of the pump (such as coupling) must be covered so that one cannot touch them. Those covers must not be dismantled while the pump is running. Dangers that results from electrical connections must be removed. To

get more information about this subject, you can refer to domestic electrical instructions.

3.4. Safety Measures for Maintenance and Installation

The customer must assure that all maintenance, check and installation tasks are performed by qualified personnel. Repair work must only be performed while the machine is not running. The pump and its auxiliary system must be cleaned thoroughly if it contains hazardous liquids. At the end of the repair work, all safety and protective equipment must be re-installed.

3.5. Spare Parts Replacement

Replacement of spare parts and all modifications must be done after contacting with the manufacturer. Spare parts and accessories certified by the manufacturer are important for the safe operation of the system.

Notice: MASDAF MAKINA SANAYI A.Ş. is not responsible from the usage of improper spare parts.

4. TECHNICAL INFORMATION

4.1. Design

KMU, OMK & OMKV, KME & KMEV pumps are non self-priming, multistage, horizontal or vertical radially split ring section pumps. While KMU, OMK, KME series have horizontal shaft, OMKV and KMEV series have vertical shaft.

4.1.1. Flange Positions – Flanges

In KMU, OMK, KME series, as a standard, discharge casing is at motor side on the top and suction casing is at dead end side on the right viewed from. Direction of rotation of the pump is clockwise viewed from driver.

In OMKV and KMEV series as a standard, discharge flange is at the motor side on the top and suction flange is on the bottom. When viewed from driver it turns clockwise.

Suction flanges are according to DIN 2533, while discharge flanges are according to DIN 2535.





4.1.2. Auxiliary Fittings

Please refer to the technical drawing of the pump for necessary auxiliary fittings.

4.1.3. Impeller

The impellers are balanced dynamically and they are close type and with single entry in both series.

4.1.4. Shaft

The shafts of multistage pumps are manufactured from chromium alloy stainless steels. The pump shaft has the same diameter along the shaft. With its special design and by using precision manufacturing methods, factors what to constitute notch effect on the shaft are kept to a minimum.

4.1.5. Bearing and Lubrication

In KMU, OMK, KME series, the shaft carrying the impellers is supported between bearings on both sides. In OMKV and KMEV pumps, there is a carrier bearing and radial and axial loads are carried by it. Also there is a journal bearing on bottom side with water lubricated.

In our standard production, pumps with oil-lubricated bearings are shipped without oil inside. Before starting the pump, the oil level must be checked from the oil indicator. If the oil level cannot be seen from the indicator, add oil from the filling plug on the bearing housing. It should be ensured that the oil used is high quality, has a high operating temperature range and high oxidation resistance. For example, Shell Tellus T46 or equivalent oil is recommended.

In grease-lubricated pumps, a small amount of grease should be pressed from the plug on the bearing covers before the first start-up so that the grease does not reach to the point of leakage. Pressing too much grease will cause an increase in the bearing temperature. It should be ensured that the grease used is high quality, has a high operating temperature range and high oxidation resistance. For example, Shell Alvania RT3, Castrol Pyroplex Blue NLGI2 or equivalent grease is recommended.



Pump Type	RPM	Number of Stage	Bearing Type	Qty.
KMU 25	-	-	6304 C3	2 Pcs
KMU 32	-	-	6304 C3	2 Pcs
KMU 40	-	-	6304 C3	2 Pcs
KMU 50	-	-	6304 C3	2 Pcs

Pump Type	RPM	Number of Stage	Bearing Type	Qty.
OMK 32	1500	2-14	6305 C3	2 Pcs
OMK 40	1500	2-12	6305 C3	2 Pcs
OMK 50	1500	2-11	6306 C3	2 Pcs
OMK 65	1500	2-11	6307 C3	2 Pcs
OMK 80	1500	2-10	6309 C3	2 Pcs
OMK 32	3000	2-9	6305 C3	2 Pcs
		10-12	6405 C3	2 Pcs
OMK 40	3000	2-7	6305 C3	2 Pcs
		8-10	6405 C3	2 Pcs
OMK 50	3000	2-5	6306 C3	2 Pcs
		6-7	6406 C3	2 Pcs
OMK 65	3000	2-3	6307 C3	2 Pcs
		4-5	6407 C3	2 Pcs
OMK 80	3000	2-3	6309 C3	2 Pcs
		4-5	6409 C3	2 Pcs

Pump Type	RPM	Number of Stage	Bearing Type	Qty.
OMKV 32	-	-	6405 C3	1 Pcs
OMKV 40	-	-	6405 C3	1 Pcs
OMKV 50	-	-	6406 C3	1 Pcs
OMKV 65	-	-	6407 C3	1 Pcs
OMKV 80	-	-	6409 C3	1 Pcs

Pump Type	RPM	Number of Steps	Bearing Type	Qty.
KMEV 100	-	-	3309 C3	1 Pcs
KMEV 125	-	-	3310 C3	1 Pcs
KMEV 150	-	-	3312 C3	1 Pcs
KMEV 200	-	-	3314 C3	1 Pcs



Pump Type	Balancing Part	Bearing Type	Qty.	Bearing Type	Qty.
KME 80	-	3308 C3	1 Adet	NU 308	1 Pcs
	Disc	-	-	NU 308	2 Pcs
KME 100	-	3309 C3	1 Adet	NU 309	1 Pcs
	Disc	-	-	NU 309	2 Pcs
KME 125	-	3310 C3	1 Adet	NU 310	1 Pcs
	Disc	-	-	NU 311	2 Pcs
	Drum	7312	2 Adet	NU 312	1 Pcs
KME 150	-	3312 C3	1 Adet	NU 312	1 Pcs
	Disc	-	-	NU 313	2 Pcs
	Drum	7314	2 Adet	NU 314	1 Pcs
KME 200	-	3314 C3	1 Adet	NU 314	1 Pcs
	Disc	-	-	NU 314	2 Pcs
	Drum	7316	2 Adet	NU 316	1 Pcs

Table 1: Pump Bearing Information

4.1.6. Sızdırmazlık

One of the following sealing types can be used. As a standard, soft packing is used in pumps having horizontal shaft, while mechanical seal is used in pumps having vertical shaft.

4.1.6.1. Design With Soft Packing

The packed stuffing box without external block must always have a slight leak for discharging the frictional heat.

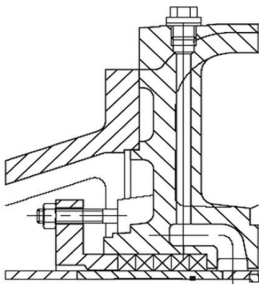

Figure 1: Packed stuffing box on the discharge side (standard)

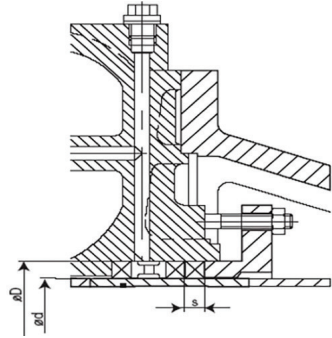

Figure 2: Packed stuffing box on the suction side (standard)

4.1.6.2. Design With Mechanical Seal

Stationary seal rings will always show some function-related drip leakage.

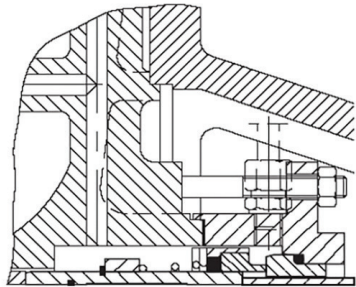

Figure 3: Mechanical Seal

4.2. Construction of Pump Group

4.2.1. Drive

TEFC (Totally Enclosed Fan Cooled) 3 phase, squirrel caged, in accordance to DIN 42673, for horizontal type IMB3, for vertical type IMB5 type electrical motor which complies with DIN IEC and VDE is used to drive the pump in proper speed and power.





Specifications of electrical motor:

isolation Class	: F
Protection Class	: IP 54-IP 55
Frequency	: 50 Hz.
Running Type	: S1
Start-Up Type	: Up to 2 kW 1x220V (Monophase) Up to 4 kW 3x380V (Y) More than 4 kW 3x380(Δ) + (Y/ Δ)

4.2.2. Coupling and Coupling Guard

A flexible shaft coupling with or without secondary component in accordance with DIN 740 is used. A coupling guard is given in accordance with EN 953+A1 in case of the pump group includes the coupling and chassis.



Pump can only be run with a couplingguard in accordance with EN 953+A1 according to safety instructions. If there is no coupling cover, it is provided by the operator.

4.2.3. Base Plate

It is manufactured from U profile steel in accordance with DIN 24259.

5. TRANSPORT AND STORAGE

Suction, discharge and all auxiliary fittings must be closed during transport and storage. Dead-end covers must be removed while the pump unit is being installed.

5.1. Transport

Pump and pump group must be carried safely to the installation location by lifting equipments.

CAUTION

Current general lifting safety instructions must be applied. Please use a suspension system shown in figure while you are carrying and lifting the pump unit. The suspension rings may be broken because of the excessive load and may result in adamage of the pump. Prefer fabric cable for suspension.

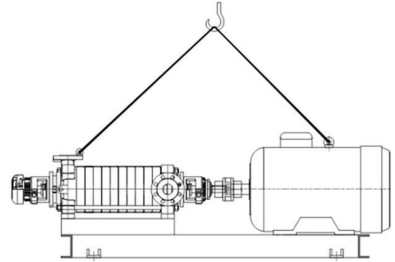

Figure 4: Transport of Pump Group (Horizontal Version)

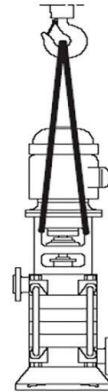

Figure 5: Transport of Pump Group (Vertical Version)

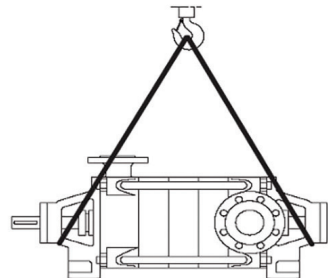

Figure 6: Transport of Pump Group (Bareshaft Pump)





Incorrect lifting may damage the pump unit and cause injuries.

Damages caused in transport

Check the pump when it is delivered to you. Please let us know if there is any damage.

5.2. Storage



Please keep the unit clean, dry and closed area during storage

If the pump is out of use for a long time, please consider the instructions below.

1. If there is water inside the pump, drain it.
2. Clean the pump casing and impeller by jetting clean water for a short time.
3. Empty water inside the pump casing, suction line and discharge line.
4. Add small amount of antifreeze inside the pump casing if it is not possible to empty it completely. Rotate the pump shaft by hand to mix the antifreeze.
5. Close the suction and discharge exits with gasket
6. Spray an anti-corrosive into the pump casing.
7. Rotate the pump shaft by hand once in every month, in order to protect it from freezing and to lubricate the bearings.

6. ASSEMBLY / INSTALLATION

6.1. Installation

In our standard production, the pump and the motor have been installed in a common base plate.

6.1.1. Location of Installation

Pump shall be installed in a location where the control and the maintenance of the pump are easily made. The pump room shall be suitable for operation of lifting systems such as freight elevator, forklift, etc.

The pump group should be installed in the lowest possible location of the pumping system in order to achieve the highest suction pressure.

6.1.2. Location of Installation- Local Ambient Temperature

When the local ambient room temperature exceeds +40°C in a pumping system, suitable ventilation should be provided in order to remove the heat dissipated to the environment and supply fresh air.

6.2. Type of Connection

Type of connection depends on the design type and the size of the pump and the motor, as well as the local installation conditions. Foot-mounted horizontal pump-motor units have been installed in a common base plate.

6.3. Piping

6.3.1. General



- Do not use the pump as the hinged support for the piping system.
- Put enough supports under the piping system in order to carry the weight of the pipe and fittings.
- Avoid piping system loads on pump by installing flexible components (compensator) to suction and discharge of the pump.
- By mounting flexible supporting items, take into consideration the fact that these items may elongate under the pressure.
- Suction pipe shall be in a constantly increasing slope to the pump. Air in the suction pipe shall be arranged to move into the pump.





- Discharge piping shall be in a constantly increasing slope to the reservoir or discharge point, without up and downs which can cause air pockets in the piping system. At locations where forming of air pockets is possible, special items like air valve and air cock are mounted to evacuate the trapped air.
- It is important that pipe diameter and fittings are at least as much as the pump opening diameter or preferable one or two size higher. One should never use fittings with smaller diameters than the pump exit diameter. In particular, preferred fittings like foot valve, strainer, filter, check valves and valves shall have large free passing area, and low friction loss coefficient.
- For piping systems with hot liquids, thermal expansions are to be taken into account and compensators shall be mounted in accordance with these expansions. Caution shall be exercised to avoid the loading of pump in this installation.

6.3.2. Specification of Work in Piping Installation



In installation of pipes, follow the procedures below certainly.

- Take out the guards (placed by the manufacturer) from suction and discharge openings of the pump.
- Close the suction and discharge flanges with rubber gaskets. This precaution is important to avoid the undesired substances (weld crust, weld slag, sand, stone, wood piece etc.) get into the pump. Do not take off this gasket until the installation is completed.
- Start the installation of piping from the pump side. Do the necessary assembling and welding of the parts in a successive order.
- In these operations, do not neglect to put the necessary supports in their respected locations.
- Following above procedure, complete all piping system at suction side up to the suction tank (or foot valve if available), at discharge side up to do discharge collector and discharge pipe.
- When all installation and welding process is done and the heat dissipated by welding is removed, dismantle all the bolted connections from the suction tank to discharge pipe. Take out all demountable parts.
- Clean these parts and then paint body coat completely inside and outside.
- Mount the parts again in their intended places. However, this time start from the discharge line and move downward to the pump. In this instance, do not forget to check the flange gaskets. If needed, (for example deformation during welding) replace them.
- Concerning the connection of the pump flanges to piping, in case of misalignment of axis and flange holes, do not force the system to eliminate the misalignment. Forcing the system may cause difficult-to-correct problems.
- If there is an axial misalignment between the flanges of the pump and the pipe, due to the welding or any other reasons, cut the pipe from a suitable location in order to fix the problem. Connect the pipe (pump side) to the pump. After carrying out the necessary correction, connect the parts again by welding.
- Dismantle and clean the last welded part. Repaint again and mount on its place.
- After all these processes are accomplished, remove the rubber gasket from the suction and discharge openings. Open their holes and mount them again on their intended place.





6.3.3. B Specification of Work after Installation of Piping and Piping System

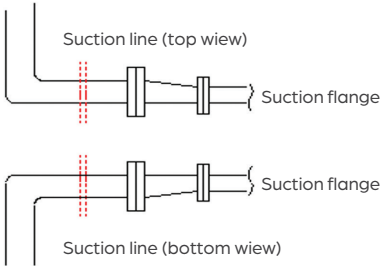

Figure 7: Piping System

Appropriate manometers shall be mounted on suction and discharge pipe lines.



Complete the auxiliary pipe connections in piping system if exist (cooling to bearing housing, and stuffing box (seal), relief pipe, oil pipe etc.)

6.4. Motor Connection

Motor shall be connected by an electrical technician according to the connection (switch) diagram. Local electricity policies regulations have to be applied.



- Electrical connections have to be made by authorized electricians.
- In dismantling the pump, make sure the electricity is cut off before taking the motor cover out.
- Use the appropriate electrical connection to the motor.



Never operate pump units not connected electrical cable connections correctly.

6.4.1. Motor Connection Diagram

Motors requiring high moments at start up shall not be connected star-delta.

Frequency controlled motors, require high moment at start up and have to be cooled properly at low speeds. Provide the necessary cooling for the motors.

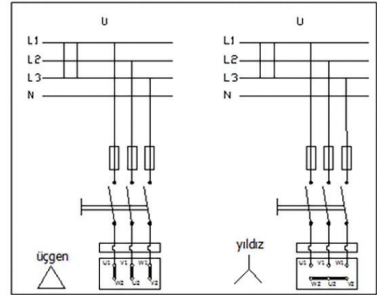

Figure 8: Motor Connection Diagram

Electrical Circuit	Motor	
U (Volt)	230/400 V	400 V
3 x 230 V	Delta	-
3 x 400 V	Star	Delta

6.4.2. Motor Protection

- Three phased-motor shall be connected to power supply.
- Wait the motor to cool down when thermic protected motor breaks in circuit due to the overheating. Make sure the motor does not start automatically until it cools completely
- In order to protect the motor from overcharging and short circuit use a thermic or thermic-magnetic relay. Adjust this relay to the nominal current of the motor.





Electrical equipments, terminals and the components of the control systems may carry electric current even though they are not operating. They may cause deadly and serious injuries or irreparable material damages.

6.5. Coupling Alignment

6.5.1. General

For a proper operation of a pump group, a good alignment of the coupling is necessary. Vibration, noise, overheating of the bearings, overcharge problems can be attributed to the misalignment of coupling or using an improper coupling.



Flexible coupling does not correct the axial misalignments between the pump and the motor axes. However, it allows pinpointing the misalignments.

In order to avoid overheating, vibration, noise and wearing of the rolling bearings, alignment of the coupling has to be made properly and checked often.

Do not use a different coupling other than the original type installed on pumping group.

6.5.2. Method of Coupling Alignment

In order to make the alignment of the coupling, it is required to have at least two pieces of about 10 cm tall, smooth-edged metal parts (e.g. a steel ruler or a gauge stick) and one precision calipers. (Figure 9) (For more precision alignments, special apparatus can be used).

Coupling misalignments in general are of two kinds

1. Parallel Axis Misalignment

(Figure 10 – Figure 12 – Figure 14)

In order to control parallel axis misalignment, a smooth edged gauge stick is pressed axially over

the upper half of the coupling. Then, the gauge stick is checked for the other half of the coupling. For alignment, the gauge stick shall be in contact with both of the halves at the same time. This procedure shall be repeated for four sides of the coupling. (i.e. top, bottom, left and right sides of the coupling). When all four sides give reasonably accepted results, alignment of the coupling has been ensured.

2. Angular Misalignment

(Figure 11 – Figure 13 – Figure 15)

In order to control the angular misalignment, the distance between the two halves of the coupling is measured in both horizontal and vertical planes. Measurements taken at four points shall be in agreement for the alignment.

Misalignments can be in horizontal or vertical planes. Misalignments in horizontal plane can be fixed by placing sheet iron at the bottom of the pump or motor base, while misalignments in vertical plane can be fixed by sliding the pump or the motor in horizontal plane.

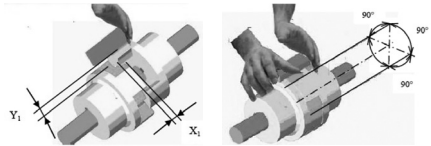

Figure 9: The Control of the Coupling Alignment in Horizontal and Vertical Planes

Figures below illustrate the possible coupling misalignments and the methods to correct them.

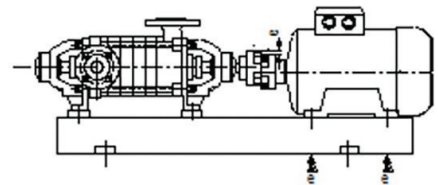

Figure 10: Parallel Axis Misalignment in Vertical Plane and Its Correction (KMU, OMK, KME)



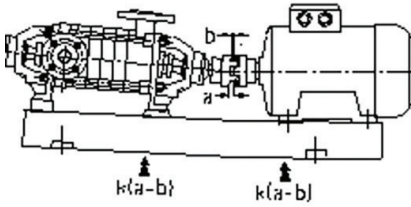

Figure 11: Angular Misalignment in Vertical Plane and Its Correction (KMU, OMK, KME)

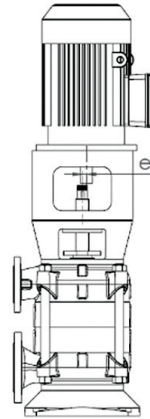

Figure 14: Parallel Axis Misalignment in Horizontal Plane and Its Correction (OMKV, KMEV)

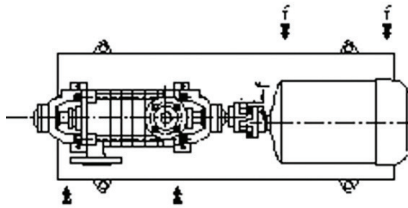

Figure 12: Parallel Axis Misalignment in Horizontal Plane and Its Correction (KMU, OMK, KME)

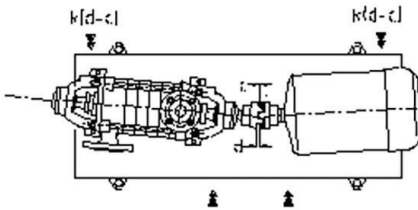

Figure 13: Angular Misalignment in Horizontal Plane and Its Correction (KMU, OMK, KME)

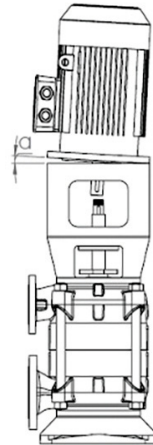

Figure 15: Angular Misalignment in Vertical Plane and Its Correction (OMKV, KMEV)





Install the coupling guard only when the alignment of the coupling is checked.

For centrifugal pumps, coupling alignment tolerances are critical to ensuring proper alignment. Coupling alignment tolerances can vary depending on a variety of factors, including coupling diameter, operating speeds, and the accuracy required by the application.

In general, coupling alignment tolerances are determined by the following parameters:

Axial Tolerance (Axis Misalignment): The amount of axial misalignment between the axes.

Angular Tolerance (Angular Alignment): The angular difference between two shafts.

Parallelism Tolerance (Lateral Alignment): The lateral misalignment of the centerlines of two shafts.

Recommended coupling alignment tolerances based on coupling diameter:

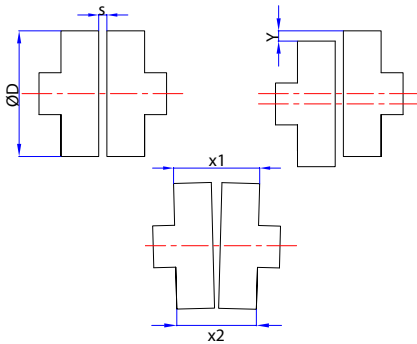

Coupling Diameter ØD(mm)	Axial Clearance S (mm)	Axial (mm)	Parallelism Y (mm)	Angularity X (mm/100mm)
69	3	0.05	0.05	0.05
78 - 96	4	0.1	0.1	0.1
106 - 200	5	0.2	0.2	0.2
224 - 400	6	0.2	0.2	0.2
450 - 550	8	0.25	0.25	0.25



6.5.3. Pump and Motor Mounting (Coupling)

If the coupling of the pump group is to be mounted on site, the following procedure should be followed.

1. Coat the shaft tip of the pump and the motor sides with a sheet of molybdenum disulfide.
2. Push the coupling halves with a driving apparatus towards the pump and the motor shafts, until the shaft is fit to snag to the hub of the coupling. If a driving apparatus is not available, heating coupling halves (with coupling rubbers off) to an approximately 100 °C may help the pushing. It is important that axial force is prevented from occurring while mounting the coupling. Support pump shaft from the impeller side, and motor shaft from the fan side while mounting the coupling. If necessary, dismantle the fan cover.
3. Screw the two bolts in coupling hub.
4. Make sure that a suitable spacing is left between the coupling halves while mounting pump and the rotor.
5. Horizontal pump groups mounted on the base plate or directly mounted on the base, alignment of the coupling shall be as described in 6.5.2.
6. Put into place the coupling guard.



According to the accident prevention regulations, all preventions and protective devices should be in their intended place and in operational form.

7. COMMISSIONING, START UP AND OPERATING

7.1. Preparations Before Start Up

OIL CHECK: Pump is provided from both sides with high temperature resistant, life long lubricated (oil), care-free (2RS type) rolling bearings



- Check pump seals
- Make sure that the pump and the suction pipe is completely filled with water before the starting. If the pump operates on a positive suction head, no problem will be encountered. Suction valve is opened and air drains are un-tightened.
- Pumps with foot valve are filled with water by opening the pump filling tap or, one takes advantage of the water accumulated in the discharge pipe and by using a small valve the check valve is bypassed and the pump is filled.
- In vacuum pump driven pumps, by operating the vacuum pump one achieves to fill the pump via increasing the water level in the suction pipe.
- Check that the pump shaft rotates easily by hand.

CAUTION

Do not start the pump dry (WITHOUT WATER)!

7.2. Checking The Direction of Rotation

CAUTION

- The direction of rotation is indicated on the pump label with an arrow. Apart from special cases, it is clockwise direction when looking from the motor end. Observe if the pump is rotating in the expected sense by starting the motor for a very short instant. If it is turning in the opposite sense, interchange any of two motor leads.
- If the motor connection is delta, open the discharge valve slowly.
- If the motor connection is star-delta, set the time relay to maximum 10 seconds. Monitor the passage from star to delta by pressing the start button. As soon as you are assured that the connection is delta, open the discharge valve slowly. Continue opening the valve until you read the amperage on the electrical panel
- One should always check the labels which show the direction of rotation and the direction of fluid flow. If you dismount the

coupling protection to monitor the direction of rotation, do not restart the engine before remounting the protection.



As a result of getting in touch with rotating and stable parts each other temperature increase can occur. Never check the direction of rotation while the pump is dry.

7.3. Start up Procedure

- Check if the suction valve is open and the discharge valve is closed. Start the motor
- Wait until the motor reaches sufficient speed. (In Star-delta connections, wait until the engine passes to delta connection.)
- Keeping an eye on the amperage shown on the panel, open the discharge valve slowly.
- In the primary operation, if the discharge pipe is empty, do not open the valve completely. By keeping an eye on the amperage, open the valve with care regarding that it should not exceed the value indicated on pump's label.
- After opening the valve completely, check the pressure from the pump exit manometer and make sure that this value is the pump operating pressure value and is indicated on pump's label
- If the value one reads is less than the pump label value when the valve is completely open, it means that the height is miscalculated. Increase the value by narrowing the valve and bring it to pump's label value.
- If the value one reads is greater than the pump label value when the valve is completely open, it means that the height is calculated less than what it should be in reality. The device is pumping less than what is requested. Check the installation and the calculations.
- Minimum flow rate: If the pump is working with zero flow rates (closed valve) from time to time during its operation, the water inside the pump may endanger the pump by getting warmed up. In such cases, a minimum flow valve must be connected to the pump exit.





CAUTION

Stop the motor if the pump gets too hot. Wait until it gets cold. Then start the system up again carefully.

7.4. Shut Down Procedure

CAUTION

During sudden start ups and stops, a pressure reducing valve must be placed at the exit section of high flow rate pumps whose discharge pipelines are long, in order to reduce water hammer effect. Water hammer may explode the pump. In normal conditions (apart from sudden power shut down, etc), stop the pump as below:

- Close the discharge valve slowly
- Switch the power off, stop the motor. Notice that the rotor slows down.
- Do not start up the motor at least before 1 to 2 minutes.
- If the pump will be out of use for a long time, close the suction valve and auxiliary circuits. If the pump is outside and if there exists a danger of frost, remove all drain taps and empty all the water inside the pump. (5.2. Storage)

CAUTION

If the pump is outside and if there exists a danger of frost, remove all drain taps and empty all the water inside the pump.

8. MAINTENANCE

CAUTION

- Maintenance operations must be done by authorized personnel with protective clothing only. The personnel must also beware of high temperatures and harmful and/or caustic liquids. Make sure that the personnel read carefully the manual.
- The instructions in Safety Precautions must be executed during maintenance and repair.



- Continuous monitoring and maintenance will increase the engine's and pump's lives.

8.1. The Checks During the Operation

- Pump must never be operated without water.
- Pump must not be operated for a long time with the discharge valve closed (zero capacity).
- Bearing temperature must never exceed 90°C if the ambient temperature is 30°C
- Precautions must be taken against flare up when the component temperatures are over 60°C. "Hot Surface" warnings must be placed over necessary areas.
- All the auxiliary systems must be in use while the pump is operating.
- Water must drop from the glands of stuffing boxes (20-30 drops per minute)
- Gland nuts must not be tightened too much. If the amount of water increases after a long operation time, the nuts may be tightened by 1/6 turns.
- If the pump has mechanical sealing, there is no need for excessive maintenance. Water leakage from the mechanical sealing indicates the fact that the sealing is worn out and therefore needs to be replaced.
- If the system consists of a substitute pump, keep it ready by operating it once a week. Check also the auxiliary systems of the substitute pump.
- Check the elastic components of the coupling. Replace them when necessary.



The air of the pump and suction line must be drained before commissioning of the pump. The interior of the pump contacting with pumped liquid including gasket way and auxiliary systems must be filled with pumped liquid.

- Ensure that delivery pressure is enough.
- Do not operate the pump at values above pressure, temperature or motor speed values specified by manufacturer, never use improper liquids with the pump.



- In oil and grease lubricated pumps, be sure to comply with the oil addition or change periods. Oil addition or change periods should be determined by the managements since they will vary depending on the operating conditions and operating times of the pumps in the plants. Never mix different types of oils.

Recommended oil change periods:

Speed (rpm)	Change Period
3000	1500 working hours
1500	2500 working hours
1000	4000 working hours

8.1.1. Component Check

CAUTION

To make possible the visual control, one must be able to reach the pump from any direction. Especially, to be able to dismount the internal units of the pump and the engine, sufficient free space must be created around them for maintenance and repair. Furthermore, one must make sure that the piping system can easily be dismounted.

8.1.1.1. Bearing and Lubrication

KMU, OMK, KME series pumps are provided from both sides with high temperature resistant, life long lubricated, care-free bearings. In OMKV and KMEV series pumps, there is a journal bearing (Graphite-Carbon) carrying radial loads on the bottom of the pump with water lubricated. Besides there is a bearing carrying radial and axial loads on the motor side.

8.1.2. Shaft Seal Maintenance

8.1.2.1. Soft Packing

- Before replacing the soft packing, the gland must be dismounted first. Used packing rings may be taken off by a sharp pointed tool. Take off the lantern ring if it exists, then clean the interiors of the sealing box, the gland and the lantern ring.

- Wrap a proper sized, good quality sealing over the shaft bush and make sure that the bush tip is completely covered.
- Place the first ring, its joint facing upwards and push it to its bed by using the gland
- If it exists push the watering ring to its bed.
- Place also the other rings to their beds alternating, i.e. their joints facing upwards and downwards.
- After placing the last ring, position the gland and tighten it completely. Thus, the squeezed sealing rings take the shape of the sealing box.
- Then un-tighten the nuts. Rotating the shaft tighten them slowly again. When you feel that the shaft is put on a brake, stop the tightening.
- Water must come from the seals drop by drop as soon as the pump is started. The number of drops must not be less than 10 and not more than 30 per minute. Find the proper setting by tightening and un-tightening the opposite gland nuts.



- Ensure that the water leaking from the sealing is collected and/or discharged in a manner which is appropriate in terms of safety and environmental criteria.
- Check the sealing temperature two hours after the gland adjustment is made. For a system which pumps water at ambient temperature, the sealing temperature must not exceed 80°C.



The pumps that working with high temperature liquids has applications on cooling sealing.

CAUTION

When tightening the gland nuts do not work with long sleeve shirts. Otherwise it is possible to get caught by the turning shaft and get injured.





8.1.2.2. Mechanical Seal

Mechanical Seals are absolutely leak tight and needs less maintenance than soft packing.

Mechanical seal;

1. Provides leak proof operation in heavy operating conditions (in waste water pumps, chemical process and refinery pumps).
2. Easily mountable and needs less maintenance.
3. Does not cause wearing on the shaft
4. Sealing operation does not depend on the quality of shaft finishing.

8.1.3. Coupling

Coupling adjustment must be checked regularly.



Worn out elastic bands must be replaced.

8.1.4. Drive

Apply to the operating instructions of the motor manufacturer.

8.1.5. Auxiliary Components

Check regularly the fittings and the gaskets, replace the worn out pieces.

8.2. Service

Our After Sales Services Department provides service support. Manager should employ authorized and trained personnel for mounting/dismounting procedures. Before these procedures, one must make sure that pump interior is clean and empty.

This criterion is also valid for the pumps which are sent to our factory or to our service points.



Maintain the safety of the personnel and the environment in every field procedure.



8.3. Spare Parts

The spare parts of pumps are guaranteed for 10 years by **MASDAF MAKINA SANAYI A.Ş.**

In your spare parts requests, please indicate the below listed values that are indicated on your pump's label.

Pump type and size:
Motor power and speed:
Pump serial number:
Capacity and head:

If you wish to keep spare parts in store, depending on the number of same type of pumps, for two operation years, the quantities which are listed in the table below are recommended.

Part Name	Pump number (including stand-by pump)						
	2	3	4	5	6-7	8-9	>9
Shaft (+keys)	1	1	2	2	2	3	30%
Impeller (set)	1	1	1	2	2	3	30%
Ball Bearing (set)	1	1	2	2	3	4	50%
Teflon	1	1	2	2	3	4	50%
O-ring (set)	4	8	8	8	9	12	150%
Mech. Seal (set)	2	3	4	5	6	7	90%
Soft Packing (set)	4	6	8	8	9	12	150%
Sleeves	2	2	2	3	3	4	50%

Table 2: Spare Part List

9. NOISE LEVEL AND VIBRATION

The reasons which increase the noise level are indicated below:

- Touch of coupling halves due to worn rubber sleeves (incorrectly aligned)
- Noise level increases due to the fact that the pump is not founded properly (Vibration)
- If the installation does not have compensator noise and vibration increases.
- Wearing in ball bearing also increases noise level.



Check if there is any noise increasing elements in your installation.

9.1. Expected Noise Values

Measurement conditions:

- The distance between the measure : 1m point and the pump
- Operation : Without Cavitation
- Motor : IEC standard motor
- Tolerance : ± 3 dB

Motor Rated Power Requirements PN [kW]	Measuring surface noise pressure level LpA [dB]* for pump with motor	
	PN [kW]	2900 d/d
0.75	50	58
1.1	53	62
1.5	55	62
2.2	56	63
3	58	65
4	60	66
5.5	64	70
7.5	65	71
11	68	73
15	69	74
18.5	69	74
22	70	75
30	71	75
37	72	76
45	73	77
55	73	79
75	74	81
90	74	82
110	75	83
132	76	84

Table 3: Sound Pressure Level

(*) Without protective sound hood, measured at a distance of 1 m directly above the driven pump, in a freespace above a sound reflecting surface.

The above values are maximum values. The surface noise pressure level at dB(A) unit is shown as (LpA). This complies with TS EN ISO 20361.

10. DISASSEMBLY, REPAIR AND REASSEMBLY



Before starting work on the pump set, make sure it is disconnected from the mains and can not be switched on accidentally.

Follow the safety precautions outlined in "Safety instructions".

10.1. Disassembly

- Close all valves in the suctions and discharge lines. Drain the water in the pump.
- Remove coupling guard and other safety guards.
- Unscrew the bolts of the suction and discharge flanges and pump foot. Separate the pump from the installation.
- Disconnect the pump from the motor and from the base plate.
- Separate the coupling from the shaft and dismantle the coupling key by using a pull-off device.



- Before starting to disassemble the pump, brand suction, discharge and stage casing and mark confronting locations for the purpose of convenience during installation.
- Unscrew the nuts of the connection bolts and remove the bolts.
- Continue the process from the suction end for easy disassembly.
- Dismantle the bearing cover on the suction end.





- Unscrew the shaft nut in front of the bearing.
- Unscrew the nuts connecting suction side bearing housing to the suction casing and remove bearing housing together with ball bearing.
- Remove suction casing off stage casing group.
- Remove spacer sleeve and seal sleeve and take out split sleeve parts.
- Remove in sequence space sleeve, impellers, stage casings together last stage diffuser.
- Unscrew the nuts connecting discharge casing to the discharge side bearing housing and remove the discharge casing.
- Remove the bearing cover.
- Remove the bearing nut and spacer sleeve behind of bearing Pull off the discharge side bearing housing together with bearing from the pump shaft, using a pull-off device.
- Clean all the parts, replace damaged or worn-out ones.

10.2. Reassembly

- Reassembly proceeds in reverse sequence to disassembly as described in section. You may find the attached drawings useful.
- Coat the seats and screw connections with graphite, silicon or similar slippery substance before reassembly. If you cannot find any of the above you may use oil instead (except the pumps for drinking water)



- Never use the old gaskets, make sure the new gaskets and o-rings are the same size as the old ones.
- Start reassembling the pump from the discharge end. Put split sleeve halves in position and slip seal sleeve and space sleeve on position.
- Mount the discharge casing to discharge side bearing housing and stuffing box and insert the shaft and bearing in its place. Screw shaft nut.
- Reassemble the last stage diffuser and impeller. Make sure discharge opening side

of the impeller corresponds exactly to the center of the diffuser.

- Reassemble the other stages in sequence carefully. Make sure that O-rings are placed correctly and do not turn.
- Put suction side split sleeve parts in position and slip seal sleeve and space sleeve on it.
- Fit the casing studs and tighten them slightly, after placing suction side bearing housing and ball bearing, then screw the bearing nut on the shaft.
- Put the pump on a horizontal flat place and by this way arrange the pump foot in a line. As tightening the casing studs carefully and uniformly rotate the rotor by means of coupling. It is necessary to rotate the rotor by hand without any stresses and compulsion.
- Place the pump on the baseplate, mount the electric motor, and connect the suction and discharge pipes and auxiliary pipes. Start up the system as shown on part 7.



Check whether the faces contacting with other faces are damaged for avoiding explosion before reassembling of the motor. The parts having deformed faces must be replaced. Ensure that the rotating parts are fitted with the guards.

10.3. Safety Precautions for Maintenance and Assembly

The operating company must ensure that all maintenance, intermediate control and assembly works are carried out by authorized and qualified personnel who comply with the operating instructions.

Work on the machine should only be done when the machine is at a standstill. Requires that the instructions for shutting down the machine described in these operating instructions are always followed.

Pumps and sets pumping unsanitary liquids must be thoroughly cleaned. At the end of the





work, all safety and protective equipment must be fitted and put into working condition. Before commissioning, the instructions in the "preparation for commissioning" section must be followed.

10.4. Spare Part Replacement

Parts replacement and modification should only be made after consultation with the manufacturer. Manufacturer-approved replacement parts and accessories are essential for safety.

NOTE: Inappropriate use of parts **MASDAF MAKINA SAN. A.Ş.** not responsible.



While the failures are repaired the pump must always be dry and un-pressurized.

POSSIBLE FAILURES	CAUSES	SOLUTIONS
Pump is not pumping!	Impeller out of balance or clogged.	Disassemble pump and inspect for dry-running damage. Clean the impeller.
	Suction line and/or discharge line closed at fitting.	Open the fitting.
	Suction line and/or discharge line closed at fitting.	Open the fitting.
	Suction pipe cross-section too narrow.	Increase cross-section. Remove encrustations from suction pipe. Open the fitting completely.
	Transport cover still in place.	Remove transport cover. Disassemble pump and inspect for dry-running damage.
	Suction pipe not bled properly or not filled up completely.	Fill completely and bleed pump and/or piping.
	Suction line contains air enclosures.	Mount fitting for bleeding. Correct the piping layout.
	Air sucked in.	Seal the source of malfunction.
	Excessive amount of gas: Pump cavitated.	Consult with manufacturer.
	Discharge pipe blocked.	Clean the discharge piping.
	Pump running in the wrong direction.	Swap any two phases at the motor.
Motor speed insufficient.	Compare required motor speed with specification on pump type plate. Replace motor if necessary. Increase adjustable motor speed if applicable.	





POSSIBLE FAILURES	CAUSES	SOLUTIONS
Pumping rate insufficient!	Impeller out of balance or clogged.	Disassemble pump and inspect for dry-running damage.
	Hydraulic components of the pump dirty, clotted or encrusted.	Disassemble pump. Clean the components.
	Motor running on 2 phases.	Check fuse; replace fuse if necessary. Check cable connections and insulation.
	Suction line not fully opened.	Open the fitting.
	Suction pipe cross-section too narrow.	Increase cross-section. Remove encrustations from suction pipe. Open the fitting completely.
	Suction head too high: NPSHpump larger than NPSHinstallation.	Increase supply pressure. Consult with manufacturer.
	Air sucked in.	Seal the source of malfunction.
	Excessive amount of gas: Pump cavitated.	Consult with manufacturer.
	Pumped medium temperature too high: Pump cavitated.	Increase supply pressure. Lower the temperature. Inquire with manufacturer.
	Viscosity or density of the pumped medium outside the specification range for the pump.	Consult with manufacturer.
	Geodetic pump head and/or pipe flow resistance too high.	Remove sediments in pump and/or pressure pipe. Install larger impeller; consult with manufacturer.
	Discharge-side fitting not opened sufficiently.	Open the pressure-side fitting.
	Discharge pipe blocked.	Clean the discharge piping.
	Pump running in the wrong direction.	Swap any two phases at the motor.
Motor speed insufficient.	Compare required motor speed with specification on pump type plate. Replace motor if necessary. Increase adjustable motor speed if applicable.	
Pump components worn.	Replace had worn pump components.	
Pumping rate too high!	Discharge-side fitting opened too wide.	Throttle down at pressure-side fitting. Mill down the impeller. Consult with manufacturer and adjust impeller diameter.
	Geodetic differential head, pipe flow resistance and/or other resistance lower than specified.	Throttle down flow rate at pressure-side fitting. Observe the minimum flow rate limit. Mill down the impeller. Consult with manufacturer and adjust impeller diameter.
	Viscosity lower than expected.	Mill down the impeller. Consult with manufacturer and adjust impeller diameter.
	Motor speed excessively high.	Compare required motor speed with specification on pump type plate. Replace motor if necessary. Reduce adjustable motor speed if applicable.
	Impeller diameter too large.	Throttle down flow rate at discharge-side fitting. Observe the minimum flow rate limit. Mill down the impeller. Consult with manufacturer and adjust impeller diameter.



POSSIBLE FAILURES	CAUSES	SOLUTIONS
Pumping pressure too low!	Impeller out of balance or clogged.	Disassemble pump and inspect for dry-running damage.
	Hydraulic components of the pump dirty, clotted or encrusted.	Disassemble pump. Clean the components.
	Motor running on 2 phases.	Check fuse; replace fuse if necessary. Check cable connections and insulation.
	Suction line not fully opened.	Open the fitting.
	Suction pipe cross-section too narrow.	Increase cross-section. Remove encrustations from suction pipe. Open the fitting completely.
	Suction head too high: NPSHpump larger than NPSHinstallation.	Increase supply pressure. Consult with manufacturer.
	Air sucked in.	Seal the source of malfunction.
	Excessive amount of gas: Pump cavitated.	Consult with manufacturer.
	Pumped medium temperature too high: Pump cavitated.	Increase supply pressure. Lower the temperature. Inquire with manufacturer.
	Viscosity or density of the pumped medium outside the specification range for the pump.	Consult with manufacturer.
	Geodetic differential head, pipe flow resistance and/or other resistance lower than specified.	Throttle down flow rate at discharge-side fitting. Observe the minimum flow rate limit. Mill down the impeller. Consult with manufacturer and adjust impeller diameter.
	Pump running in the wrong direction.	Swap any two phases at the motor.
	Motor speed insufficient.	Compare required motor speed with specification on pump type plate. Replace motor if necessary. Increase adjustable motor speed if applicable.
Pump components worn.	Replace had worn pump components.	
Pumping pressure too high!	Discharge-side fitting not opened sufficiently.	Open the discharge-side fitting.
	Discharge pipe blocked.	Clean the discharge piping.
	Viscosity lower than expected.	Mill down the impeller. Consult with manufacturer and adjust impeller diameter.
	Motor speed excessively high.	Compare required motor speed with specification on pump type plate. Replace motor if necessary. Reduce adjustable motor speed if applicable.
	Impeller diameter too large.	Throttle down flow rate at discharge-side fitting. Observe the minimum flow rate limit. Mill down the impeller. Consult with manufacturer and adjust impeller diameter.



POSSIBLE FAILURES	CAUSES	SOLUTIONS
Pump running roughly!	Impeller out of balance or clogged.	Disassemble pump and inspect for dry-running damage.
	Hydraulic components of the pump dirty, clotted or encrusted.	Disassemble pump. Clean the components.
	Antifriction bearing in bearing bracket defective.	Replace antifriction bearings.
	Pump distorted.	Check pipe connections and pump fixation. Check coupling alignment. Check support foot fixation.
	Coupling not properly aligned.	Align coupling.
	Coupling packets worn.	Replace coupling packets and realign.
	Motor running on 2 phases.	Check fuse; replace fuse if necessary. Check cable connections and insulation.
	Suction pipe cross-section too narrow.	Increase cross-section. Remove encrustations from suction pipe. Open the fitting completely.
	Suction head too high: NPSH pump larger than NPSH installation.	Increase supply pressure. Consult with manufacturer.
	Suction pipe not bled properly or not filled up completely.	Fill completely and bleed pump and/or piping.
	Suction line contains air enclosures.	Mount fitting for bleeding. Correct the piping layout.
	Excessive amount of gas: Pump cavitated.	Consult with manufacturer.
	Pumped medium temperature too high: Pump cavitated.	Increase supply pressure. Lower the temperature. Inquire with manufacturer.
	Discharge-side fitting not opened sufficiently.	Open the discharge-side fitting.
	Discharge pipe blocked.	Clean the discharge piping.
	Pump running in the wrong direction.	Swap any two phases at the motor.
	Pump components worn.	Replace had worn pump components.
	Discharge-side fitting opened too wide.	Throttle down at discharge-side fitting. Mill down the impeller. Consult with manufacturer and adjust impeller diameter.
	Geodetic differential head, pipe flow resistance and/or other resistance lower than specified.	Throttle down flow rate at discharge-side fitting. Observe the minimum flow rate limit. Mill down the impeller. Consult with manufacturer and adjust impeller diameter.
	Motor speed excessively high.	Compare required motor speed with specification on pump type plate. Replace motor if necessary. Reduce adjustable motor speed if applicable.
Impeller diameter too large.	Throttle down flow rate at discharge-side fitting. Observe the minimum flow rate limit. Mill down the impeller. Consult with manufacturer and adjust impeller diameter.	



POSSIBLE FAILURES	CAUSES	SOLUTIONS
Antifriction bearing temperatures too high!	Antifriction bearing in bearing bracket defective.	Replace antifriction bearings.
	Antifriction bearing in motor defective.	Replace antifriction bearings.
	Lubricant: too much, too little or unsuitable.	Reduce or top up or replace lubricant.
	Pump distorted.	Check pipe connections and pump fixation. Check coupling alignment. Check support foot fixation.
	Coupling not properly aligned.	Align coupling.
	Pump components worn.	Replace had worn pump components.
	Motor speed excessively high.	Compare required motor speed with specification on pump type plate. Replace motor if necessary. Reduce adjustable motor speed if applicable.
Pump leaking!	Connecting screw or bolts not tightened correctly.	Tighten connecting screws and bolts.
	Mechanical seal worn.	Replace mechanical seal.
	Casing seal defective.	Replace casing seal.
	Shaft sleeve is infiltrated.	Replace the shaft sleeve and/or O-rings.
	Pump distorted.	Check pipe connections and pump fixation. Check coupling alignment. Check support foot fixation.
Motor power uptake excessive!	Antifriction bearing in bearing bracket defective.	Replace antifriction bearings.
	Pump distorted	Check pipe connections and pump fixation. Check coupling alignment. Check support foot fixation.
	Motor running on 2 phases.	Check fuse; replace fuse if necessary. Check cable connections and insulation.
	Viscosity or density of the pumped medium outside the specification range for the pump.	Consult with manufacturer.
	Discharge-side fitting opened too wide.	Throttle down at discharge-side fitting. Mill down the impeller. Consult with manufacturer and adjust impeller diameter.
	Geodetic differential head, pipe flow resistance and/or other resistance lower than specified.	Throttle down flow rate at discharge-side fitting. Observe the minimum flow rate limit. Mill down the impeller. Consult with manufacturer and adjust impeller diameter.
	Motor speed excessively high.	Compare required motor speed with specification on pump type plate. Replace motor if necessary. Reduce adjustable motor speed if applicable.
	Impeller diameter too large.	Throttle down flow rate at discharge-side fitting. Observe the minimum flow rate limit. Mill down the impeller. Consult with manufacturer and adjust impeller diameter.

Table 4: Table of Possible Failures, Causes and Solutions



12. TIGHTENING TORQUES

Thread Diameter	Tightening Torque Max (Nm)	
	Property Classes	
	8.8	10.9
M4	3.0	4.4
M5	5.9	8.7
M6	10	15
M8	25	36
M10	49	72
M12	85	125
M14	135	200
M16	210	310
M18	300	430
M20	425	610
M22	580	820
M24	730	1050
M27	1100	1550
M30	1450	2100
M33	1970	2770
M36	2530	3560

Table 5: Table of Tightening Torques





13. FORCES AND MOMENTS AT THE PUMP FLANGES

All of the applied load if not reached the maximum allowable value, to provide that the following additional conditions, one of these loads may exceed the normal limit:

- Any component of a force or a moment, must be limited 1.4 times of the maximum allowable value,
- The actual force and moments acting on each flange, should provide the following formula:

$$\left(\frac{\sum |F| \text{ actual}}{\sum |F| \text{ maximum allowable}} \right)^2 + \left(\frac{\sum |M| \text{ actual}}{\sum |M| \text{ maximum allowable}} \right)^2 \leq 2$$

In here; $\sum |F|$ ve $\sum |M|$, are arithmetic sum of the loads for each flange at the pump level, without regard of the algebraic signs of the actual and maximum allowable values.

PUMP TYPE	DN FLANGE		FORCES						MOMENTS	
			Suction Flange			Discharge Flange			Suction Flange	Discharge Flange
	Suction	Discharge	in N			in N			in Nm	in Nm
			F _y	F _z	F _x	F _y	F _z	F _x	M	M
KMU 25	25	25	243	200	214	200	243	214	280	280
KMU 32	32	32	300	243	257	243	300	257	385	385
KMU 40	40	40	357	286	314	286	357	314	490	490
KMU 50	50	50	471	386	429	386	471	429	543	543
OMK 32 / OMKV 32	50	32	471	386	429	243	300	257	543	385
OMK 40 / OMKV 40	65	40	600	486	529	286	357	314	595	490
OMK 50 / OMKV 50	80	50	714	586	643	386	471	429	648	543
OMK 65 / OMKV 65	100	65	957	771	857	486	600	529	735	595
OMK 80 / OMKV 80	100	80	857	957	771	643	586	714	735	648
KME 80	100	80	857	957	771	643	586	714	735	648
KME 100 / KMEV 100	125	100	1014	1129	914	857	771	957	893	735
KME 125 / KMEV 125	150	125	1286	1429	1157	1014	914	1129	1103	893
KME 150 / KMEV 150	200	150	1714	1914	1543	1286	1157	1429	1505	1103
KME 200 / KMEV 200	250	200	2129	2386	1929	1714	1543	1914	2118	1505

Table 6: Table of Forces and Moments at the Pump Flanges

Forces at the pump flanges were calculated according to EN ISO 5199 standard. The calculations are valid for the materials of cast iron and bronze. Forces and moments at the flanges that made of stainless material will be approximately twice as moments in the table.





14. SAMPLE PLUMPING SYSTEM

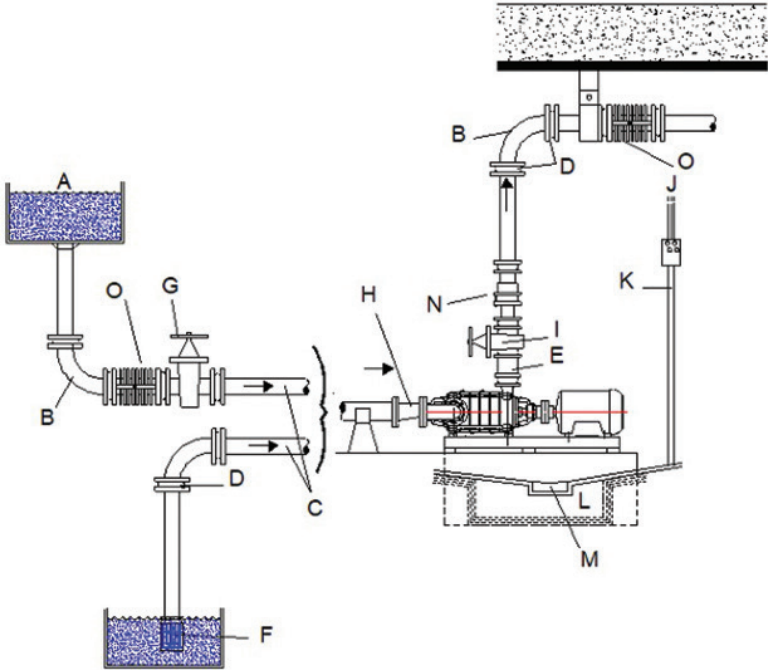

Figure 16: A typical piping for KMU, OMK and KME series

- A. Tank
- B. Large radius elbow
- C. Minimum slope is 2 cm/m
- D. Fittings, flanges etc.
- E. Non-return valve
- F. Foot valve
- G. Suction valve
- H. Reducer
- I. Discharge valve
- J. Electrical connection
- K. Insulated cable
- L. Concrete foundation
- M. Dirty water groove
- N. Compensator
- O. Compensator



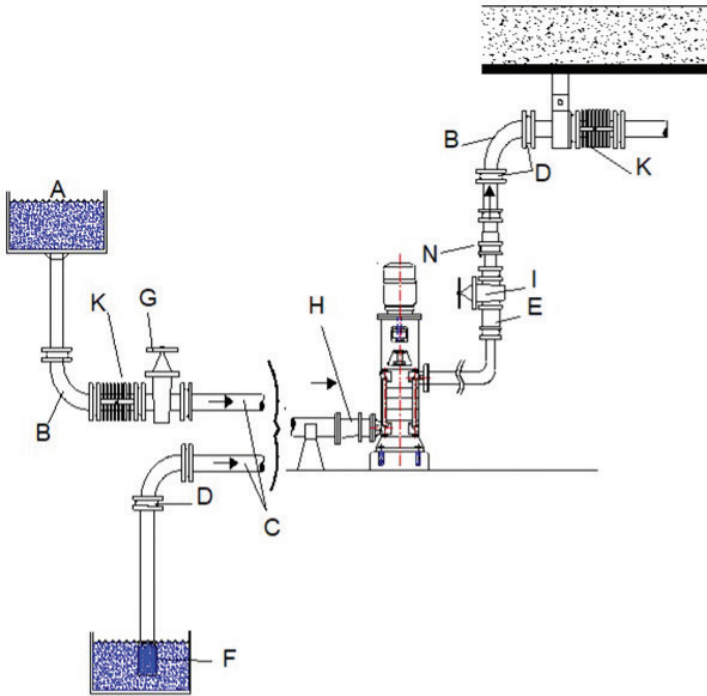

Figure 17: A typical piping for OMKV and KMEV series

- A. Tank
- B. Large radius elbow
- C. Minimum slope is 2 cm/m.
- D. Fittings, flanges etc.
- E. Non-return valve
- F. Foot valve
- G. Suction valve
- H. Reducer
- i. Discharge valve
- K. Compensator
- N. Compensator





15. SECTIONAL DRAWINGS AND PART LISTS

15.1. KMU Sectional Drawing and Part List with Mechanical Seal Design

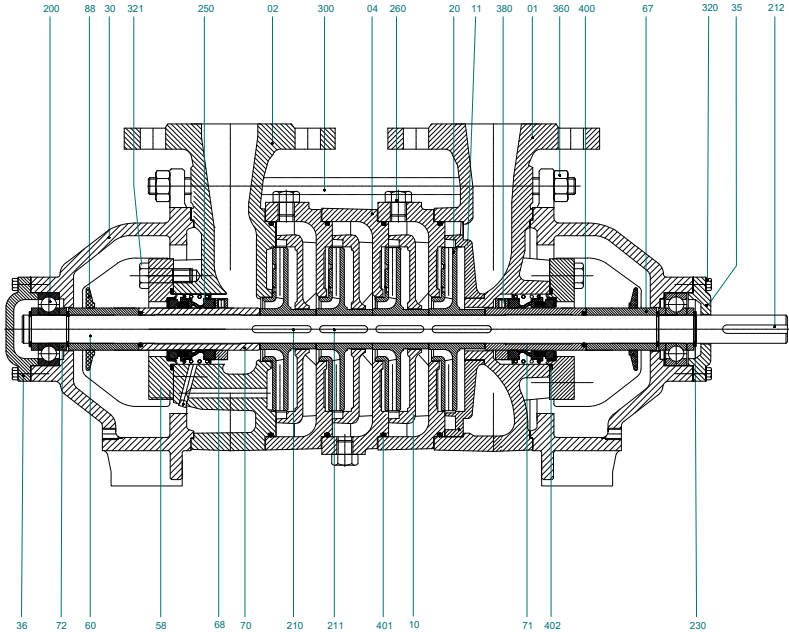

Part No	Part Name	Part No	Part Name	Part No	Part Name
1	Discharge Casing	68	Mechanical Seal	250	Mechanical Seal
2	Suction Casing	70	Seal Sleeve, Discharge	260	Pipe Plug
4	Stage Casing	71	Seal Sleeve, Suction	300	Stud For Casing
11	Last Stage Diffuser	72	Ring For Roller Bearing	320	Hex Bolt
20	Impeller	88	Thrower	321	Hex Bolt
30	Bearing Housing	200	Roller Bearing	360	Nut
35	Bearing Cover, Suction Side	210	Key, First & Last Impeller	380	Set Screw
36	Bearing Cover, Discharge Side	211	Key, Standard Impeller	400	O-Ring, Seal Sleeve
58	Mechanical Seal Cover	212	Coupling Key	401	O-Ring, Stage Casing
60	Pump Shaft	230	Ring	402	O-Ring
67	Spacer Bush				





15.2. KMU Sectional Drawing and Part List with Soft Packing Design

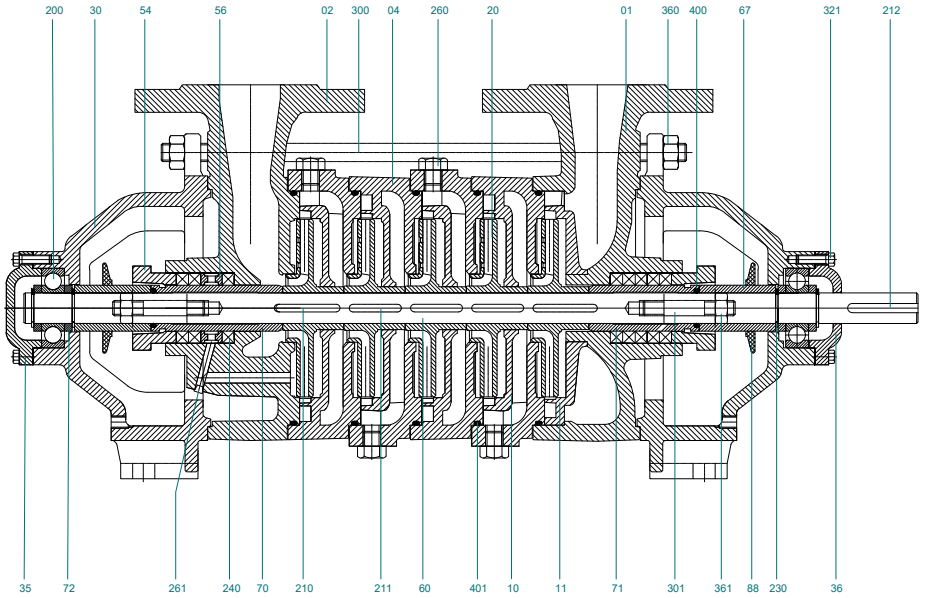

Part No	Part Name	Part No	Part Name	Part No	Part Name
1	Discharge Casing	67	Space Sleeve	240	Soft Packing
2	Suction Casing	70	Seal Sleeve, Suction	260	Pipe Plug
4	Stage Casing	71	Seal Sleeve, Discharge	261	Plug
11	Last Stage Diffuser	72	Ring	300	Stud For Casing
21	Impeller	88	Thrower	301	Gland Stud
30	Bearing Housing	200	Roller Bearing	321	Hex Bolt
35	Bearing Cover, Suction Side	210	Key, First & Last Impeller	360	Nut
36	Bearing Cover, Discharge Side	211	Key, Standard Impeller	361	Gland Nut
54	Gland	212	Coupling Key	400	O-Ring, Seal Sleeve
56	Lantern Ring	230	Ring	401	O-Ring, Stage Casing
60	Pump Shaft				





15.3. OMK Sectional Drawing and Part List with Mechanical Seal Design

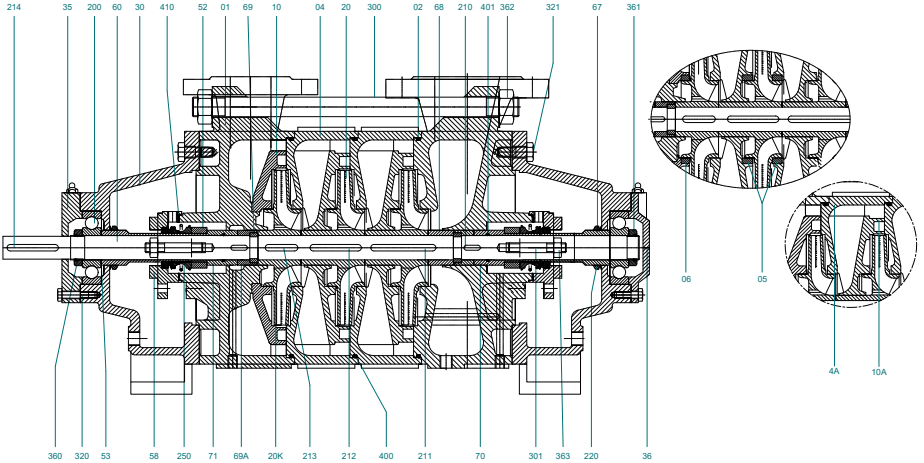

Part No	Part Name	Part No	Part Name	Part No	Part Name
1	Discharge Casing	68	Impeller Sleeve	300	Stud, Gland
2	Suction Casing	69	Split Ring	301	Casing Stud
4	Stage Casing With Diffuser	69A	Cover Ring	320	Bolt, Bearing
10	Last Stage Diffuser	70	Suction Seal Sleeve	321	Bolt, Bearing
20	Impeller	71	Discharge Seal Sleeve	360	Shaft Nut
20K	Last Stage Impeller	200	Ball Bearing	361	Shaft Nut
30	Bearing Housing	210	Key, Sleeve	362	Stud, Mech. Seal cover
35	Bearing Cover (Discharge Side)	211	Key, First Stage Impeller	363	Nut, Casing Stud
36	Bearing Cover (Suction Side)	212	Key, Standard Impeller	400	O-Ring (Stage Casing)
52	Mech. Seal Sleeve (Front)	213	Key, Last Stage Impeller	401	O-Ring (Seal Sleeve)
58	Mech. Seal Cover	214	Key, Coupling	410	O-Ring
60	Pump Shaft	220	V-Ring	420	Supporting Ring
67	Space Sleeve	250	Mechanical Seal		





15.4. OMK Sectional Drawing and Part List with Soft Packing Design

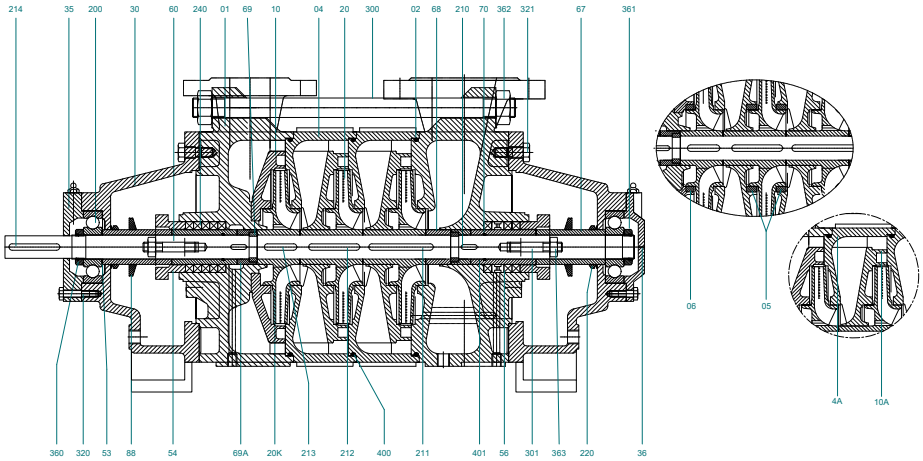

Part No	Part Name	Part No	Part Name	Part No	Part Name
1	Discharge Casing	68	Space Sleeve	240	Soft Packing
2	Suction Casing	69	Split Ring	300	Stud For Gland
4	Stage Casing With Diffuser	69A	Cover Ring	301	Casing Stud
10	Last Stage Diffuser	70	Seal Sleeve	320	Bolt, Bearing Cover
20	Impeller	88	Thrower	321	Bolt, Bearing House
20K	Last Stage Impeller	200	Ball Bearing	360	Shaft Nut
30	Bearing Housing	210	Key, Sleeve	361	Shaft Nut
35	Bearing Cover (Discharge Side)	211	Key, First Stage Impeller	362	Nut, Casing Stud
36	Bearing Cover (Suction Side)	212	Key, Standard Impeller	363	Gland Nut
54	Gland	213	Key, Last Stage Impeller	400	O-Ring (Stage Casing)
56	Lantern Ring	214	Key, Coupling	401	O-Ring (Seal Sleeve)
60	Pump Shaft	220	V-Ring	420	Gasket
67	Space Sleeve				





15.5. OMKV Sectional Drawing and Part List with Mechanical Seal Design

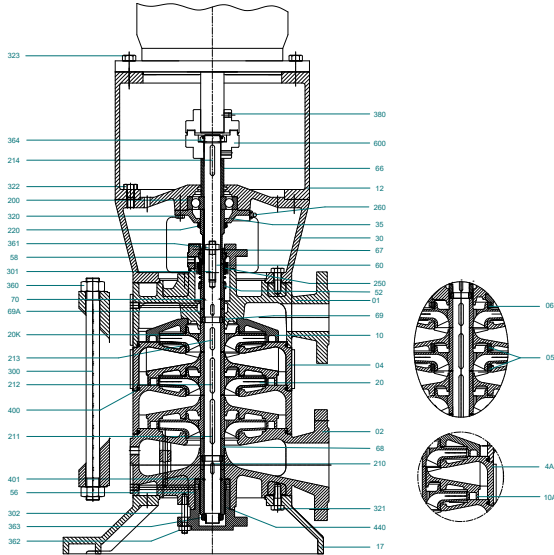

Part No	Part Name	Part No	Part Name	Part No	Part Name
1	Discharge Casing	68	Space Sleeve	302	Stud
2	Suction Casing	69	Split Ring	320	Hexagonal Bolt
4	Stage Casing With Diffuser	69A	Retaining Ring	321	Hexagonal Bolt
10	Last Stage Diffuser	70	Seal Sleeve	322	Hexagonal Bolt
12	Adapter	200	Ball Bearing	323	Hexagonal Bolt
17	Base Plate	210	Key for sleeve	360	Nut
20	Impeller	211	Key for First Stage Impeller	361	Nut
20K	Last Stage Impeller	212	Key For Standard Impeller	362	Nut
30	Bearing Housing	213	Key For Last Stage Impeller	363	Nut
35	Bearing Cover (Out)	214	Key For Coupling	364	Nut
56	Bottom Bearing Body	220	V-Ring	380	Set-Screw
58	Mechanical Seal Cover	250	Mechanical Seal	400	O-Ring
60	Pump Shaft	260	Greaser	401	O-Ring
66	Coupling Sleeve	300	Stud	440	Graphite Carbon
67	Space Sleeve	301	Stud	600	Coupling





15.6. Sectional Drawing and Part List with Soft Packing Design

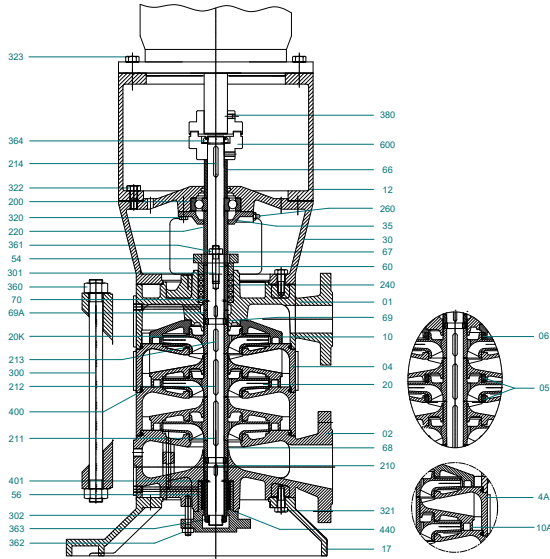

Part No	Part Name	Part No	Part Name	Part No	Part Name
1	Discharge Casing	68	Space Sleeve	302	Stud
2	Suction Casing	69	Split Ring	320	Hexagonal Bolt
4	Stage Casing With Diffuser	69A	Retaining Ring	321	Hexagonal Bolt
10	Last Stage Diffuser	70	Graphite Sleeve	322	Hexagonal Bolt
12	Adapter	200	Ball Bearing	323	Hexagonal Bolt
17	Base Plate	210	Key for sleeve	360	Nut
20	Impeller	211	Key for First Stage Impeller	361	Nut
20K	Last Stage Impeller	212	Key For Standard Impeller	362	Nut
30	Bearing Housing	213	Key For Last Stage Impeller	363	Nut
35	Bearing Cover (Out)	214	Key For Coupling	364	Nut
54	Gland	220	V-Ring	380	Set-Screw
56	Teflon Bearing Gland	240	Soft Packing	400	O-Ring
60	Pump Shaft	260	Greaser	401	O-Ring
66	Coupling Sleeve	300	Stud	440	Graphite Carbon
67	Space Sleeve	301	Stud	600	Coupling





15.7. KME Sectional Drawing and Part List with Mechanical Seal Design

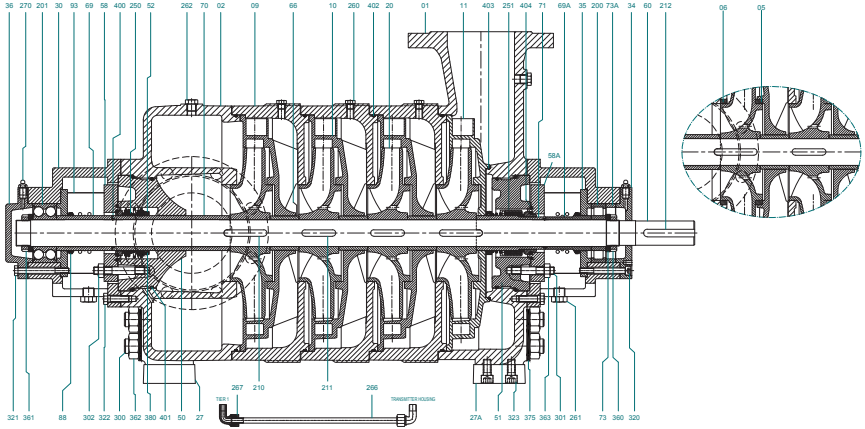

Part No	Part Name	Part No	Part Name	Part No	Part Name
1	Discharge Casing	66	Bearing Nut (Right)	267	Pipe Union
2	Suction Casing	67	Space Sleeve	270	Greaser
4	Stage Casing	67A	Suction Sleeve	300	Gland Stud
7	Wear Ring	68	Impeller Sleeve	301	Stud
10	Diffuser	69	Bearing Press Sleeve	302	Casing Stud
11	Last Stage Diffuser	70	Seal Sleeve (Disc)	303	Casing Stud
20	Impeller	71	Seal Sleeve (Suc.)	320	Hexagonal Bolt
30	Bearing Housing	72	Bearing Sleeve	321	Hexagonal Bolt
34	Bearing Cover (Inside)	200	Cylindrical Roller Bearing	340	Bolt
35	Bearing Cover (Disc)	201	Double Row Ball Bearing	341	Bolt
36	Bearing Cover (Suc.)	210	Impeller Key	360	Gland Nut
50	Stuffing Box (Disc)	211	Impeller Key	361	Nut
51	Stuffing Box (Suc.)	212	Coupling Key	362	Casing Nut
54	Mech. Seal Cover	240	Mechanical Seal	400	O-Ring
56	Lantern Ring (Suc.)	260	Plug	401	O-Ring
57	Lantern Ring (Disc)	261	Bearing Housing Plug	402	O-Ring
60	Shaft	262	Casing Plug	403	O-Ring
65	Bearing Nut (Left)	266	Watering Pipe (Disc)	404	O-Ring





15.8. KME Sectional Drawing and Part List with Mechanical Seal and Balancing Disc Design

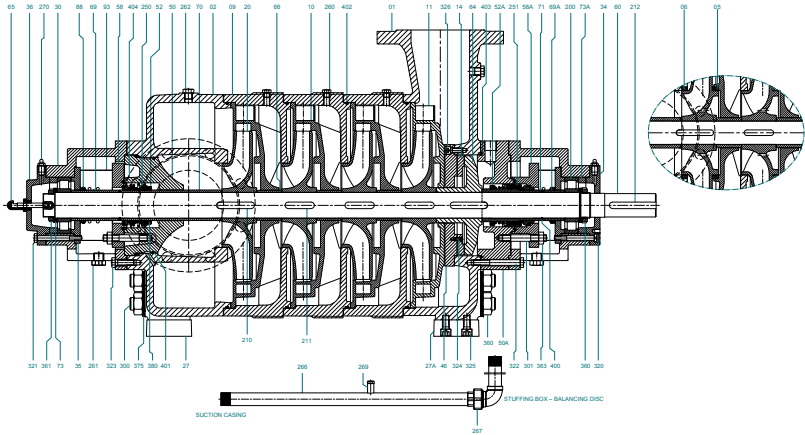

Part No	Part Name	Part No	Part Name	Part No	Part Name
1	Discharge Casing	66	Bearing Nut (Right)	266	Watering Pipe (Disc.)
2	Suction Casing	67	Space Sleeve Suc and Disc	266A	Conical Union
4	Stage Casing	69	Bearing Press Sleeve	266B	Elbow
7	Wear Ring	70	Seal Sleeve (Disc.)	266C	Nipple
10	Diffuser	71	Seal Sleeve (Suc.)	270	Greaser
11	Last Stage Diffuser B.Disc	72	Bearing Sleeve	276	B.Disc Wear Indicator
18	Balancing Disc Ring	73	Bearing Press Sleeve (Inside)	301	Stud
20	Impeller	74	Impeller Space Sleeve	302	Casing Stud
30	Bearing Housing	88	Thrower	320	Hexagonal Bolt
34	Bearing Cover (Inside)	200	Cylindrical Roller Bearing	321	Hexagonal Bolt
35	Bearing Cover (Disc.)	210	Impeller Key	322	Bolt
36	Bearing Cover (Suc.)	211	Impeller Key	340	Imbus Bolt
50	Stuffing Box (Disc.)	212	Coupling Key	341	Countersunk Bolt
51	Stuffing Box (Suc.)	240	Mechanical Seal	342	Set-Screw
54	Mechanical Seal Cover	260	Air Relief Cock	361	Nut
60	Shaft (Balancing Disc.)	261	Bearing Housing Plug	400	O-Ring (Stage)
64	Balancing Disc	262	Casing Plug	401	O-Ring (Seal Sleeve)
65	Bearing Nut (Left)	263	Plug Diffuser Stage	402	Wearing Gauge





15.9. KME Sectional Drawing and Part List with Soft Packing Design

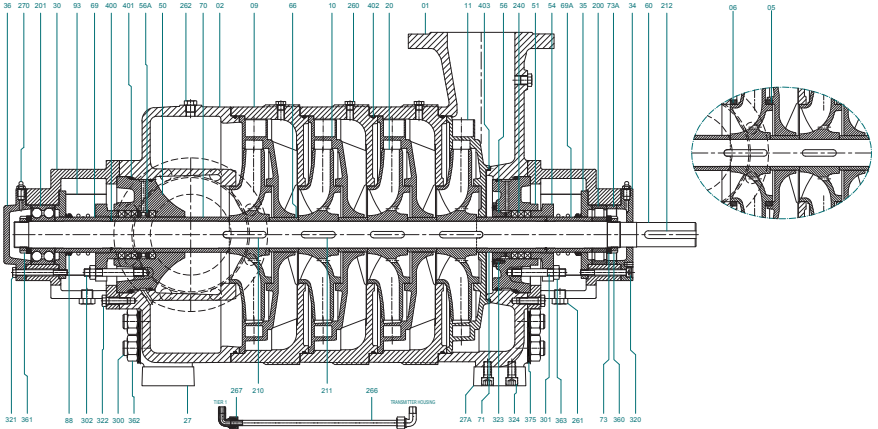

Part No	Part Name	Part No	Part Name	Part No	Part Name
1	Discharge Casing	66	Bearing Nut (Right)	266	Watering Pipe (Disc.)
2	Suction Casing	67	Space Sleeve	267	Pipe Union
4	Stage Casing	67A	Space Sleeve	270	Greaser
7	Wear Ring	68	Impeller Space Sleeve	300	Gland Stud
10	Diffuser	69	Bearing Press Sleeve	301	Stud
11	Last Stage Diffuser	70	Seal Sleeve (Disc.)	302	Casing Stud
20	Impeller	71	Seal Sleeve (Suc.)	320	Hexagonal Bolt
30	Bearing Housing	72	Bearing Sleeve	321	Hexagonal Bolt
34	Bearing Cover (Inside)	88	Thrower	322	Bolt
35	Bearing Cover (Disc.)	200	Cylindrical Roller Bearing	340	Bolt
36	Bearing Cover (Suc.)	201	Double Row Ball Bearing	341	Set-Screw
50	Stuffing Box (Disc.)	210	Impeller Key	360	Gland Nut
51	Stuffing Box (Suc.)	211	Impeller Key	361	Nut
54	Gland	212	Coupling Key	400	O-Ring
56	Lantern Ring (Disc.)	240	Soft Packing	401	O-Ring
57	Lantern Ring (Suc.)	260	Plug	402	O-Ring
60	Shaft	261	Bearing Housing Plug	403	O-Ring
65	Bearing Nut (Left)	262	Casing Plug	404	O-Ring





15.10. KME Sectional Drawing and Part List with Soft Packing and Balancing Disc Design

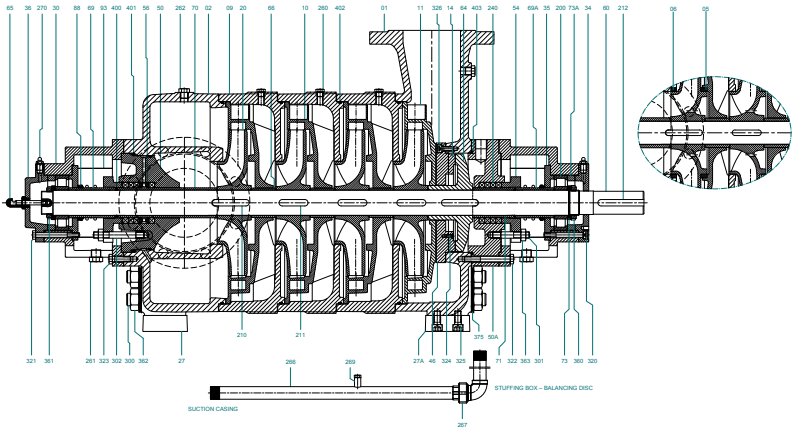

Part No	Part Name	Part No	Part Name	Part No	Part Name
1	Discharge Casing	66	Bearing Nut (Right)	266A	Conical Union
2	Suction Casing	67	Space Sleeve Suc and Disc	266B	Elbow
4	Stage Casing	69	Bearing Press Sleeve	266C	Nipple
7	Wear Ring	70	Seal Sleeve (Disc.)	270	Greaser
10	Diffuser	71	Seal Sleeve (Suc.)	276	B.Disc Wear Indicator
11	Last Stage Diffuser B.Disc	72	Suc.Bearing Press Sleeve B.Disc	300	Gland Stud (Suc.)
18	Balancing Disc Ring	73	Bearing Press Sleeve (Inside)	301	Stud
20	Impeller	74	Impeller Space Sleeve	302	Gland Stud (Disc.)
30	Bearing Housing	88	Thrower	320	Hexagonal Bolt
34	Bearing Cover (Inside)	200	Cylindrical Roller Bearing	321	Hexagonal Bolt
35	Bearing Cover (Disc.)	210	Impeller Key	322	Bolt
36	Bearing Cover (Suc.)	211	Impeller Key	340	Imbus Bolt
50	Stuffing Box (Disc.)	212	Coupling Key	341	Countersunk Bolt
51	Stuffing Box (Suc.)	240	Soft Packing	342	Set-Screw
54	Gland	260	Air Relief Cock	360	Gland Nut (Suc.)
57	Lantern Ring (Suc.)	261	Bearing Housing Plug	361	Nut
60	Shaft (Balancing Disc.)	262	Casing Plug	400	O-Ring (Stage)
64	Balancing Disc	263	Plug Diffuser Stage	401	O-Ring (Seal Sleeve)
65	Bearing Nut (Left)	266	Watering Pipe (Disc.)	402	O-Ring (Stuffing Box B.Disc)





15.11. KMEV Sectional Drawing and Part List with Mechanical Seal Design

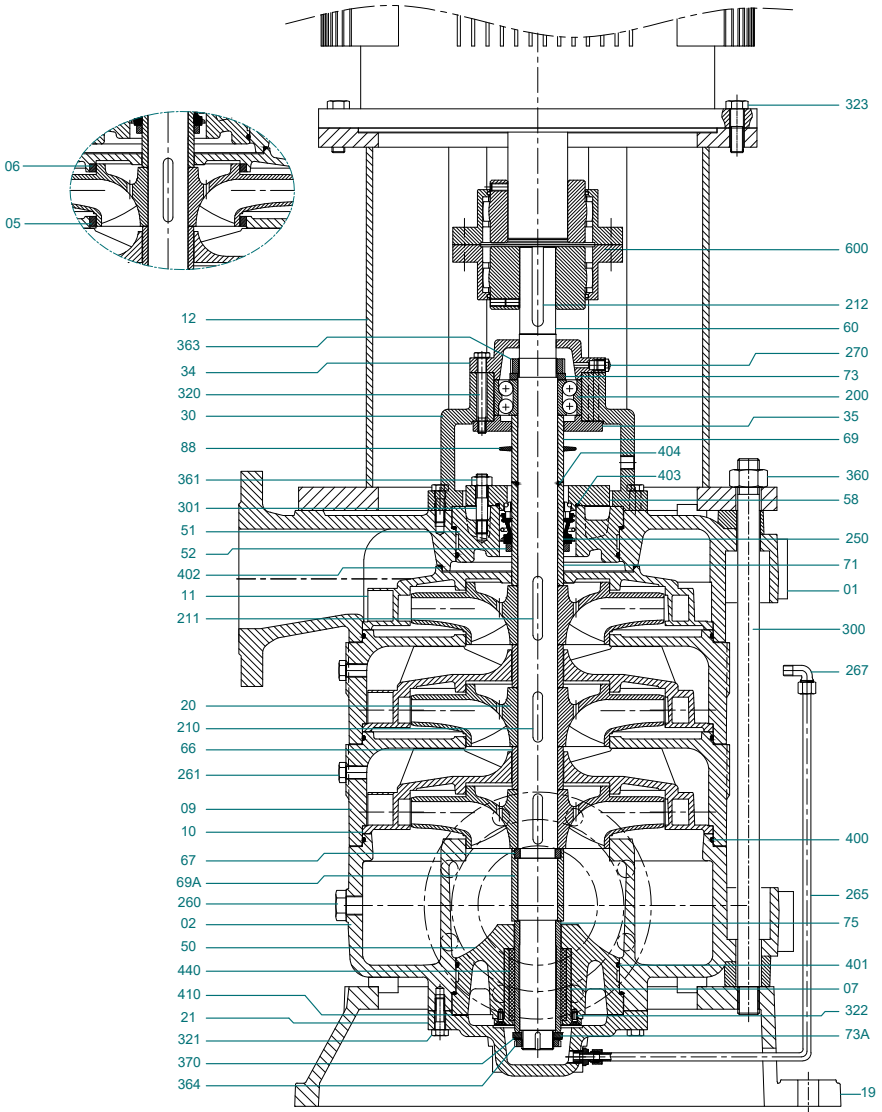



Part No	Part Name	Part No	Part Name	Part No	Part Name
1	Discharge Casing	67	Spacer Bush (Discharge)	301	Puller Stud
2	Suction Casing	69	Clipping Spacer Bushing	320	Hexagon Bolt
7	Wearing Ring	69A	Seal Spacer Bushing	321	Hexagon Bolt
9	Stage (Without Diffuser)	71	Seal Bushing	322	Hexagon Bolt
10	Diffuser	73	Bear Spacer Bushing	323	Hexagon Bolt
11	Last Stage Diffuser	73A	Spacer Washer	360	Gland Nut
12	Adaptor	75	Carbon Sleeve Bushing	361	Nut
19	Base Plate	88	V-Ring	362	Nut
20	Impeller	200	Bearing	363	Safety Nut (Right)
21	Bottom Cover	210	Impeller Key	364	Safety Nut (Left)
30	Bearing Housing	211	Impeller Key	370	Safety Sheet
34	Bearing Cover (Inner)	212	Coupling Key	400	O-Ring
35	Bearing Cover (Outer)	250	Mechanical Seal	401	O-Ring
50	Stuffing Box (Discharge)	260	Plug	402	O-Ring
51	Stuffing Box (Suction)	261	Plug	403	O-Ring
52	Mechanical Seal Sleeve	265	Irrigation Pipe	404	O-Ring
58	Mechanical Seal Cover	267	Angle Union	405	O-Ring
60	Pump Shaft	270	Greaser	440	Carbon Sleeve
66	Shaft Nut	300	Gland Stud	600	Coupling





15.12. KMEV Sectional Drawing and Part List with Soft Packing Design

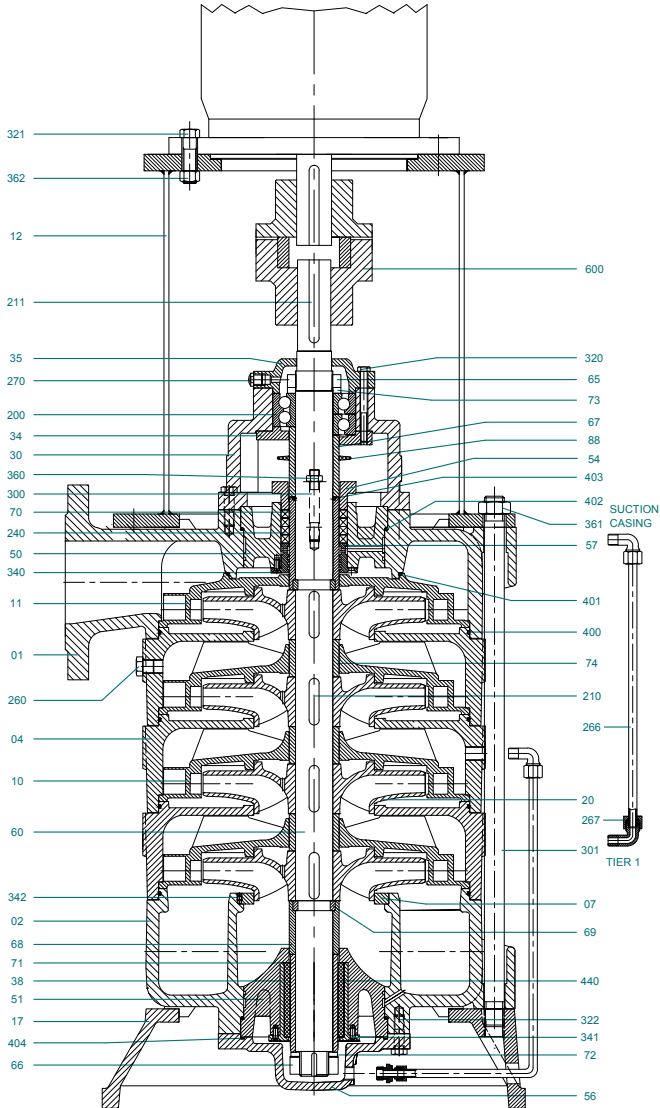



Part No	Part Name	Part No	Part Name	Part No	Part Name
1	Discharge Casing	65	Shaft Nut (Discharge)	300	Gland Stud
2	Suction Casing	66	Shaft Nut	301	Puller Stud
4	Stage (Without Diffuser)	67	Spacer Bush (Discharge)	320	Hexagon Bolt
7	Wear Ring	68	Spacer Bush (Suction)	321	Hexagon Bolt
10	Diffuser	69	Clipping Spacer Bush	322	Hexagon Bolt
11	Last Stage Diffuser	70	Seal Bushing	340	Countersunk Bolt
12	Adaptor	71	Carbon Bear Bushing	341	Countersunk Bolt
17	Base Plate	72	Bear Spacer Bushing (Suction)	342	Set Screw
20	Impeller	73	Bear Spacer Bushing (Discharge)	360	Gland Nut
30	Bearing Housing	74	Impeller Spacer Bushing	361	Nut
34	Bearing Cover (Inner)	88	V-Ring	362	Nut
35	Bearing Cover (Outer)	200	Bearing	400	O-Ring
38	Carbon Sleeve Bushing	210	Impeller Key	401	O-Ring
50	Stuffing Box (Discharge)	211	Impeller Key	402	O-Ring
51	Stuffing Box (Suction)	240	Soft Packing	403	O-Ring
54	Gland	260	Plug	404	O-Ring
56	Bottom Cover	266	Irrigation Pipe	440	Carbon Sleeve
57	Water Ring (Discharge)	267	Angle Union	600	Coupling
60	Pump Shaft	270	Greaser		





16. EXPLODED VIEWS AND PART LISTS

16.1. KMU Exploded View and Part List with Mechanical Seal Design

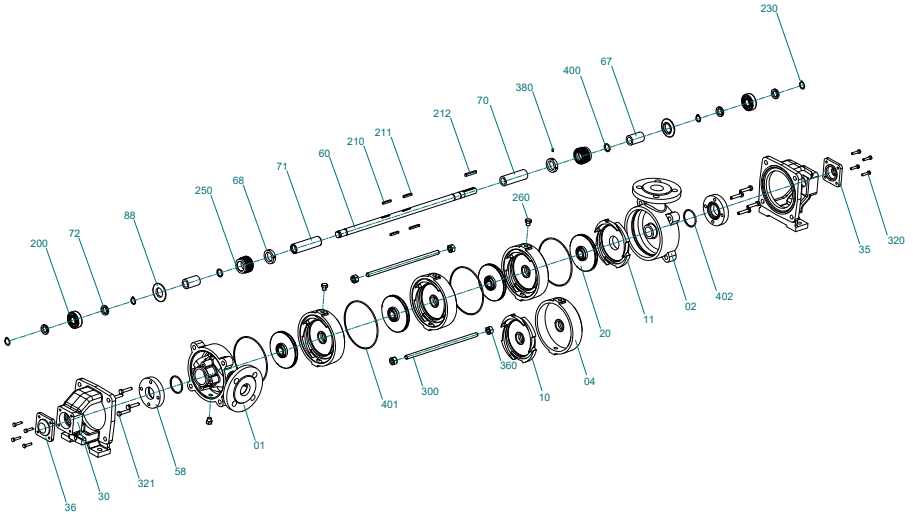

Part No	Part Name	Part No	Part Name	Part No	Part Name
1	Discharge Casing	68	Mechanical Seal	250	Mechanical Seal
2	Suction Casing	70	Seal Sleeve, Discharge	260	Pipe Plug
4	Stage Casing	71	Seal Sleeve, Suction	300	Stud For Casing
11	Last Stage Diffuser	72	Ring For Roller Bearing	320	Hex Bolt
20	Impeller	88	Thrower	321	Hex Bolt
30	Bearing Housing	200	Roller Bearing	360	Nut
35	Bearing Cover, Suction Side	210	Key, First & Last Impeller	380	Set Screw
36	Bearing Cover, Discharge Side	211	Key, Standard Impeller	400	O-Ring, Seal Sleeve
58	Mechanical Seal Cover	212	Coupling Key	401	O-Ring, Stage Casing
60	Pump Shaft	230	Ring	402	O-Ring
67	Spacer Bush				





16.2. KMU Exploded View and Part List with Soft Packing Design

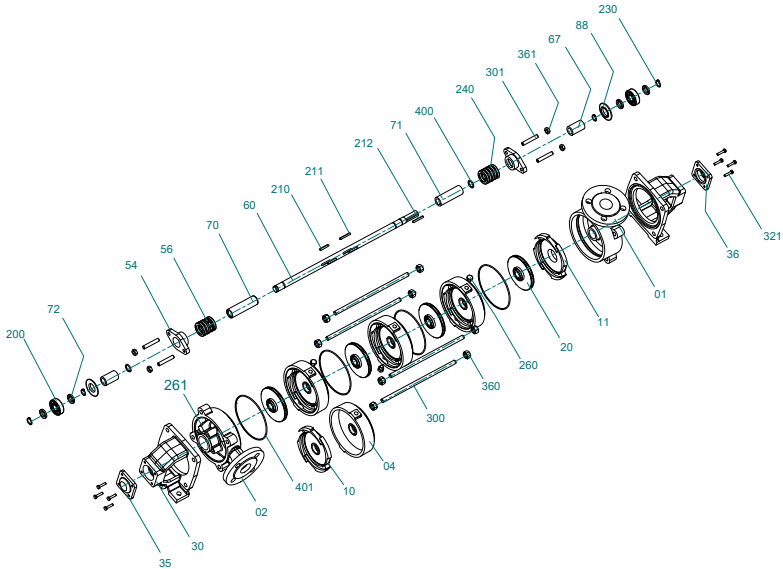

Part No	Part Name	Part No	Part Name	Part No	Part Name
1	Discharge Casing	67	Space Sleeve	240	Soft Packing
2	Suction Casing	70	Seal Sleeve, Suction	260	Pipe Plug
4	Stage Casing	71	Seal Sleeve, Discharge	261	Plug
11	Last Stage Diffuser	72	Ring	300	Stud For Casing
21	Impeller	88	Thrower	301	Gland Stud
30	Bearing Housing	200	Roller Bearing	321	Hex Bolt
35	Bearing Cover, Suction Side	210	Key, First & Last Impeller	360	Nut
36	Bearing Cover, Discharge Side	211	Key, Standard Impeller	361	Gland Nut
54	Gland	212	Coupling Key	400	O-Ring, Seal Sleeve
56	Lantern Ring	230	Ring	401	O-Ring, Stage Casing
60	Pump Shaft				





16.3. OMK Exploded View and Part List with Mechanical Seal Design

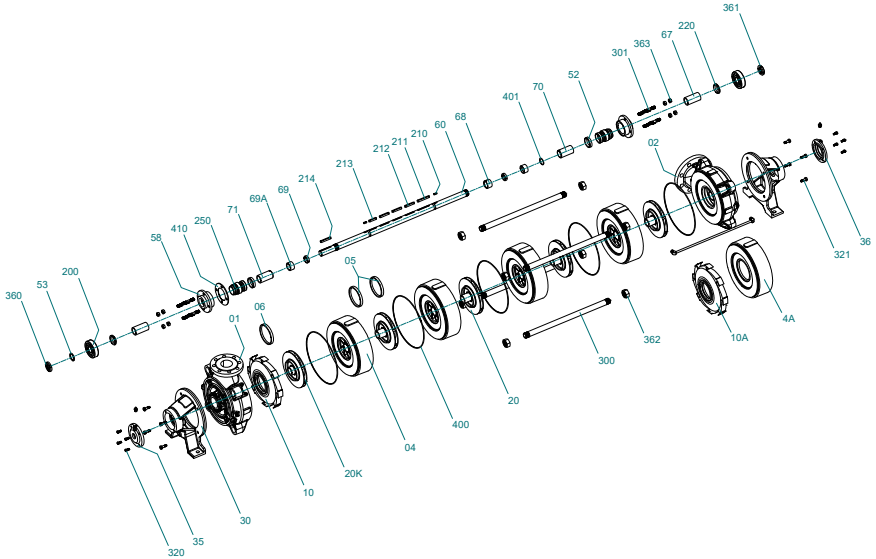

Part No	Part Name	Part No	Part Name	Part No	Part Name
1	Discharge Casing	68	Impeller Sleeve	300	Stud, Gland
2	Suction Casing	69	Split Ring	301	Casing Stud
4	Stage Casing With Diffuser	69A	Cover Ring	320	Bolt, Bearing
10	Last Stage Diffuser	70	Suction Seal Sleeve	321	Bolt, Bearing
20	Impeller	71	Discharge Seal Sleeve	360	Shaft Nut
20K	Last Stage Impeller	200	Ball Bearing	361	Shaft Nut
30	Bearing Housing	210	Key, Sleeve	362	Stud, Mech. Seal cover
35	Bearing Cover (Discharge Side)	211	Key, First Stage Impeller	363	Nut, Casing Stud
36	Bearing Cover (Suction Side)	212	Key, Standard Impeller	400	O-Ring (Stage Casing)
52	Mech. Seal Sleeve (Front)	213	Key, Last Stage Impeller	401	O-Ring (Seal Sleeve)
58	Mech. Seal Cover	214	Key, Coupling	410	O-Ring
60	Pump Shaft	220	V-Ring	420	Supporting Ring
67	Space Sleeve	250	Mechanical Seal		





16.4. OMK Exploded View and Part List with Soft Packing Design

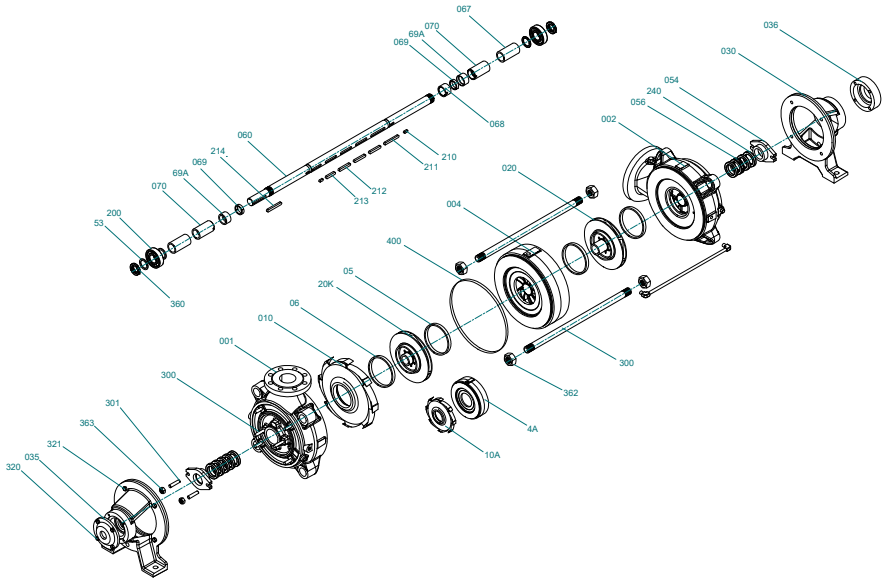

Part No	Part Name	Part No	Part Name	Part No	Part Name
1	Discharge Casing	68	Space Sleeve	240	Soft Packing
2	Suction Casing	69	Split Ring	300	Stud For Gland
4	Stage Casing With Diffuser	69A	Cover Ring	301	Casing Stud
10	Last Stage Diffuser	70	Seal Sleeve	320	Bolt, Bearing Cover
20	Impeller	88	Thrower	321	Bolt, Bearing House
20K	Last Stage Impeller	200	Ball Bearing	360	Shaft Nut
30	Bearing Housing	210	Key, Sleeve	361	Shaft Nut
35	Bearing Cover (Discharge Side)	211	Key, First Stage Impeller	362	Nut, Casing Stud
36	Bearing Cover (Suction Side)	212	Key, Standard Impeller	363	Gland Nut
54	Gland	213	Key, Last Stage Impeller	400	O-Ring (Stage Casing)
56	Lantern Ring	214	Key, Coupling	401	O-Ring (Seal Sleeve)
60	Pump Shaft	220	V-Ring	420	Gasket
67	Space Sleeve				





16.5. OMKV Exploded View and Part List with Mechanical Seal Design

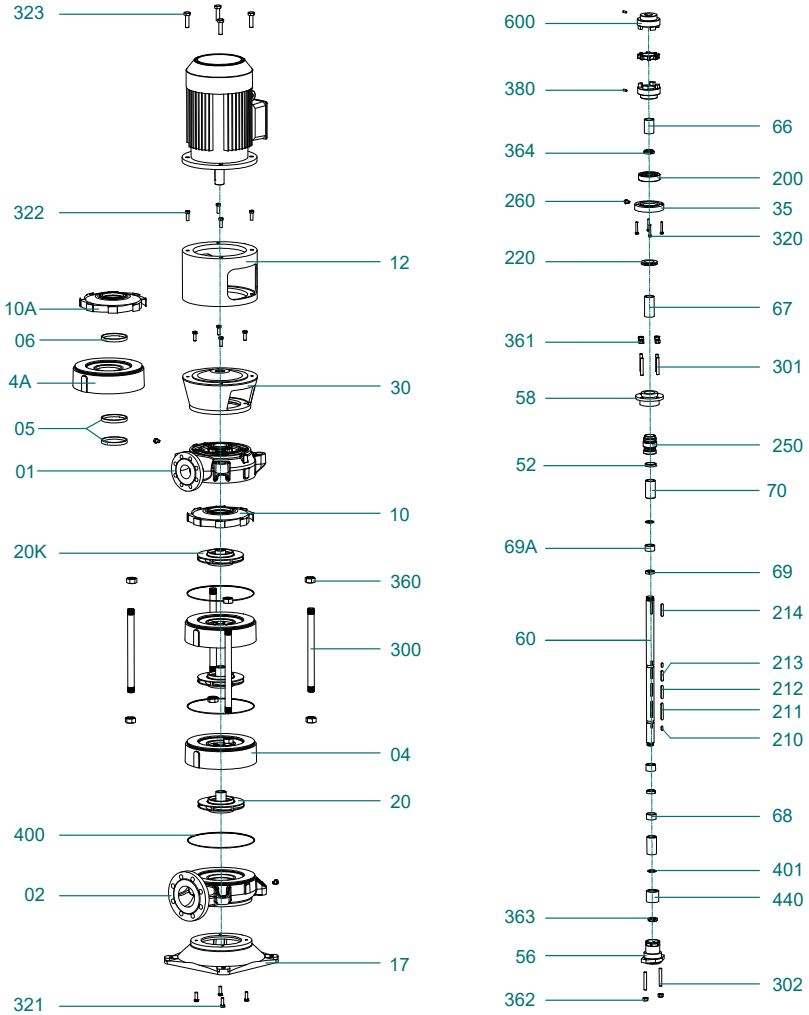



Part No	Part Name	Part No	Part Name	Part No	Part Name
1	Discharge Casing	68	Space Sleeve	302	Stud
2	Suction Casing	69	Split Ring	320	Hexagonal Bolt
4	Stage Casing With Diffuser	69A	Retaining Ring	321	Hexagonal Bolt
10	Last Stage Diffuser	70	Seal Sleeve	322	Hexagonal Bolt
12	Adapter	200	Ball Bearing	323	Hexagonal Bolt
17	Base Plate	210	Key for sleeve	360	Nut
20	Impeller	211	Key for First Stage Impeller	361	Nut
20K	Last Stage Impeller	212	Key For Standard Impeller	362	Nut
30	Bearing Housing	213	Key For Last Stage Impeller	363	Nut
35	Bearing Cover (Out)	214	Key For Coupling	364	Nut
56	Bottom Bearing Body	220	V-Ring	380	Set-Screw
58	Mechanical Seal Cover	250	Mechanical Seal	400	O-Ring
60	Pump Shaft	260	Greaser	401	O-Ring
66	Coupling Sleeve	300	Stud	440	Graphite Carbon
67	Space Sleeve	301	Stud	600	Coupling





16.6. OMKV Exploded View and Part List with Soft Packing Design

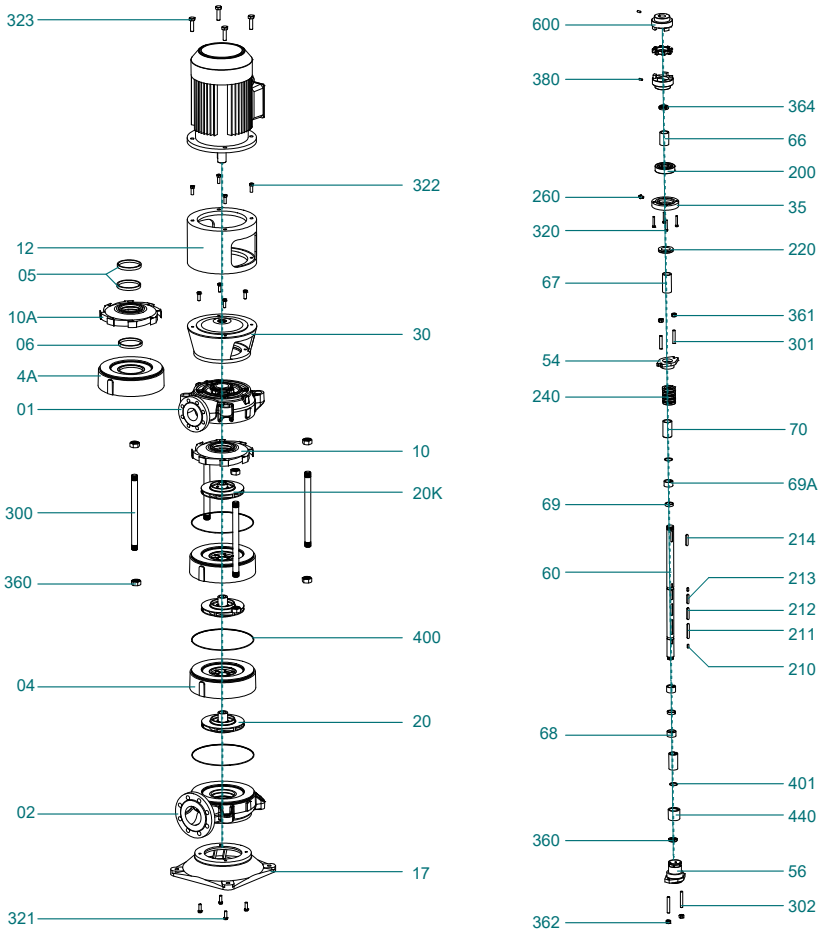



Part No	Part Name	Part No	Part Name	Part No	Part Name
1	Discharge Casing	68	Space Sleeve	302	Stud
2	Suction Casing	69	Split Ring	320	Hexagonal Bolt
4	Stage Casing With Diffuser	69A	Retaining Ring	321	Hexagonal Bolt
10	Last Stage Diffuser	70	Graphite Sleeve	322	Hexagonal Bolt
12	Adapter	200	Ball Bearing	323	Hexagonal Bolt
17	Base Plate	210	Key for sleeve	360	Nut
20	Impeller	211	Key for First Stage Impeller	361	Nut
20K	Last Stage Impeller	212	Key For Standard Impeller	362	Nut
30	Bearing Housing	213	Key For Last Stage Impeller	363	Nut
35	Bearing Cover (Out)	214	Key For Coupling	364	Nut
54	Gland	220	V-Ring	380	Set-Screw
56	Teflon Bearing Gland	240	Soft Packing	400	O-Ring
60	Pump Shaft	260	Greaser	401	O-Ring
66	Coupling Sleeve	300	Stud	440	Graphite Carbon
67	Space Sleeve	301	Stud	600	Coupling





16.7. KME Exploded View and Part List with Mechanical Seal Design

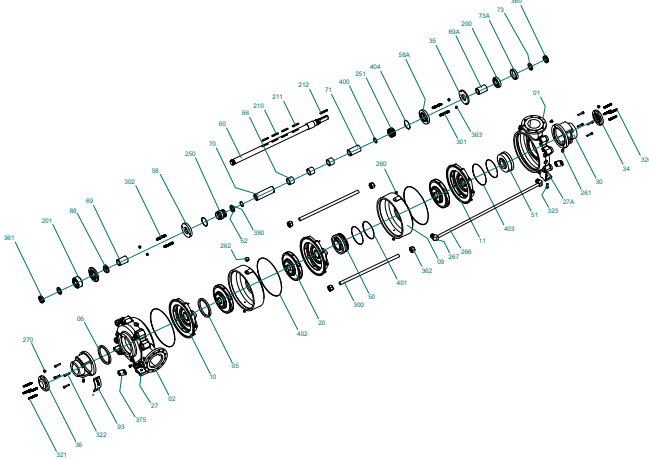

Part No	Part Name	Part No	Part Name	Part No	Part Name
1	Discharge Casing	66	Bearing Nut (Right)	267	Pipe Union
2	Suction Casing	67	Space Sleeve	270	Greaser
4	Stage Casing	67A	Suction Sleeve	300	Gland Stud
7	Wear Ring	68	Impeller Sleeve	301	Stud
10	Diffuser	69	Bearing Press Sleeve	302	Casing Stud
11	Last Stage Diffuser	70	Seal Sleeve (Disc)	303	Casing Stud
20	Impeller	71	Seal Sleeve (Suc.)	320	Hexagonal Bolt
30	Bearing Housing	72	Bearing Sleeve	321	Hexagonal Bolt
34	Bearing Cover (Inside)	200	Cylindrical Roller Bearing	340	Bolt
35	Bearing Cover (Disc)	201	Double Row Ball Bearing	341	Bolt
36	Bearing Cover (Suc.)	210	Impeller Key	360	Gland Nut
50	Stuffing Box (Disc)	211	Impeller Key	361	Nut
51	Stuffing Box (Suc.)	212	Coupling Key	362	Casing Nut
54	Mech. Seal Cover	240	Mechanical Seal	400	O-Ring
56	Lantern Ring (Suc.)	260	Plug	401	O-Ring
57	Lantern Ring (Disc)	261	Bearing Housing Plug	402	O-Ring
60	Shaft	262	Casing Plug	403	O-Ring
65	Bearing Nut (Left)	266	Watering Pipe (Disc)	404	O-Ring





16.8. KME Exploded View and Part List with Mechanical Seal and Balancing Disc Design

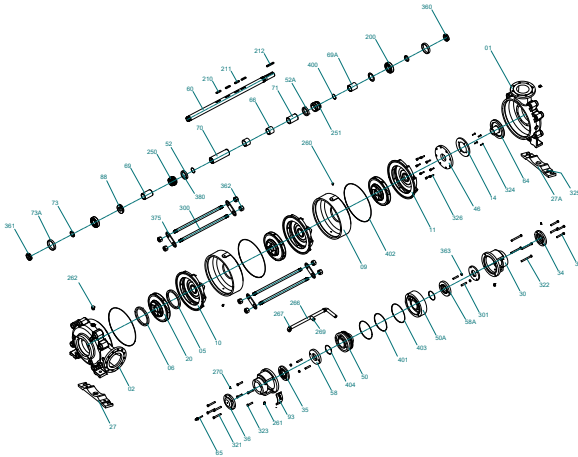

Part No	Part Name	Part No	Part Name	Part No	Part Name
1	Discharge Casing	66	Bearing Nut (Right)	266	Watering Pipe (Disc.)
2	Suction Casing	67	Space Sleeve Suc and Disc	266A	Conical Union
4	Stage Casing	69	Bearing Press Sleeve	266B	Elbow
7	Wear Ring	70	Seal Sleeve (Disc.)	266C	Nipple
10	Diffuser	71	Seal Sleeve (Suc.)	270	Greaser
11	Last Stage Diffuser B.Disc	72	Bearing Sleeve	276	B.Disc Wear Indicator
18	Balancing Disc Ring	73	Bearing Press Sleeve (Inside)	301	Stud
20	Impeller	74	Impeller Space Sleeve	302	Casing Stud
30	Bearing Housing	88	Thrower	320	Hexagonal Bolt
34	Bearing Cover (Inside)	200	Cylindrical Roller Bearing	321	Hexagonal Bolt
35	Bearing Cover (Disc.)	210	Impeller Key	322	Bolt
36	Bearing Cover (Suc.)	211	Impeller Key	340	Imbus Bolt
50	Stuffing Box (Disc.)	212	Coupling Key	341	Countersunk Bolt
51	Stuffing Box (Suc.)	240	Mechanical Seal	342	Set-Screw
54	Mechanical Seal Cover	260	Air Relief Cock	361	Nut
60	Shaft (Balancing Disc.)	261	Bearing Housing Plug	400	O-Ring (Stage)
64	Balancing Disc	262	Casing Plug	401	O-Ring (Seal Sleeve)
65	Bearing Nut (Left)	263	Plug Diffuser Stage	402	Wearing Gauge





16.9. KME Exploded View and Part List with Soft Packing Design

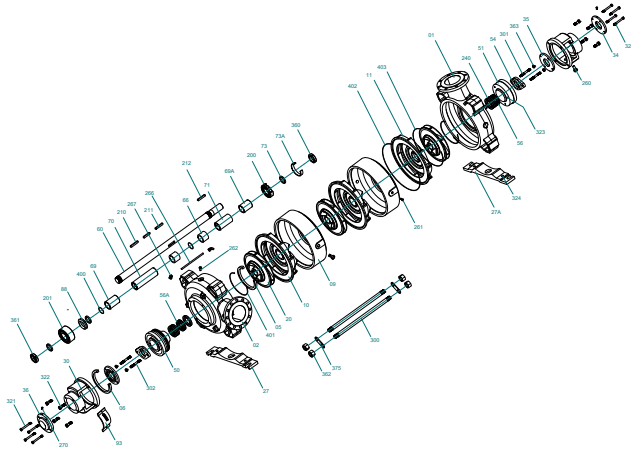

Part No	Part Name	Part No	Part Name	Part No	Part Name
1	Discharge Casing	66	Bearing Nut (Right)	266	Watering Pipe (Disc.)
2	Suction Casing	67	Space Sleeve	267	Pipe Union
4	Stage Casing	67A	Space Sleeve	270	Greaser
7	Wear Ring	68	Impeller Space Sleeve	300	Gland Stud
10	Diffuser	69	Bearing Press Sleeve	301	Stud
11	Last Stage Diffuser	70	Seal Sleeve (Disc.)	302	Casing Stud
20	Impeller	71	Seal Sleeve (Suc.)	320	Hexagonal Bolt
30	Bearing Housing	72	Bearing Sleeve	321	Hexagonal Bolt
34	Bearing Cover (Inside)	88	Thrower	322	Bolt
35	Bearing Cover (Disc.)	200	Cylindrical Roller Bearing	340	Bolt
36	Bearing Cover (Suc.)	201	Double Row Ball Bearing	341	Set-Screw
50	Stuffing Box (Disc.)	210	Impeller Key	360	Gland Nut
51	Stuffing Box (Suc.)	211	Impeller Key	361	Nut
54	Gland	212	Coupling Key	400	O-Ring
56	Lantern Ring (Disc.)	240	Soft Packing	401	O-Ring
57	Lantern Ring (Suc.)	260	Plug	402	O-Ring
60	Shaft	261	Bearing Housing Plug	403	O-Ring
65	Bearing Nut (Left)	262	Casing Plug	404	O-Ring





16.10. KME Exploded View and Part List with Soft Packing and Balancing Disc Design

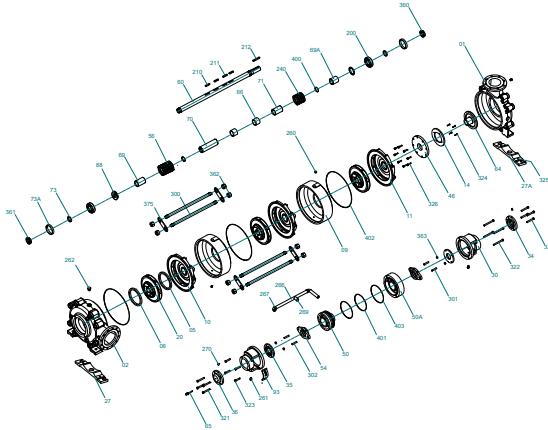

Part No	Part Name	Part No	Part Name	Part No	Part Name
1	Discharge Casing	66	Bearing Nut (Right)	266A	Conical Union
2	Suction Casing	67	Space Sleeve Suc and Disc	266B	Elbow
4	Stage Casing	69	Bearing Press Sleeve	266C	Nipple
7	Wear Ring	70	Seal Sleeve (Disc.)	270	Greaser
10	Diffuser	71	Seal Sleeve (Suc.)	276	B.Disc Wear Indicator
11	Last Stage Diffuser B.Disc	72	Suc.Bearing Press Sleeve B.Disc	300	Gland Stud (Suc.)
18	Balancing Disc Ring	73	Bearing Press Sleeve (Inside)	301	Stud
20	Impeller	74	Impeller Space Sleeve	302	Gland Stud (Disc.)
30	Bearing Housing	88	Thrower	320	Hexagonal Bolt
34	Bearing Cover (Inside)	200	Cylindrical Roller Bearing	321	Hexagonal Bolt
35	Bearing Cover (Disc.)	210	Impeller Key	322	Bolt
36	Bearing Cover (Suc.)	211	Impeller Key	340	Imbus Bolt
50	Stuffing Box (Disc.)	212	Coupling Key	341	Countersunk Bolt
51	Stuffing Box (Suc.)	240	Soft Packing	342	Set-Screw
54	Gland	260	Air Relief Cock	360	Gland Nut (Suc.)
57	Lantern Ring (Suc.)	261	Bearing Housing Plug	361	Nut
60	Shaft (Balancing Disc)	262	Casing Plug	400	O-Ring (Stage)
64	Balancing Disc	263	Plug Diffuser Stage	401	O-Ring (Seal Sleeve)
65	Bearing Nut (Left)	266	Watering Pipe (Disc.)	402	O-Ring (Stuffing Box B.Disc)





16.11. KMEV Exploded View and Part List with Mechanical Seal Design

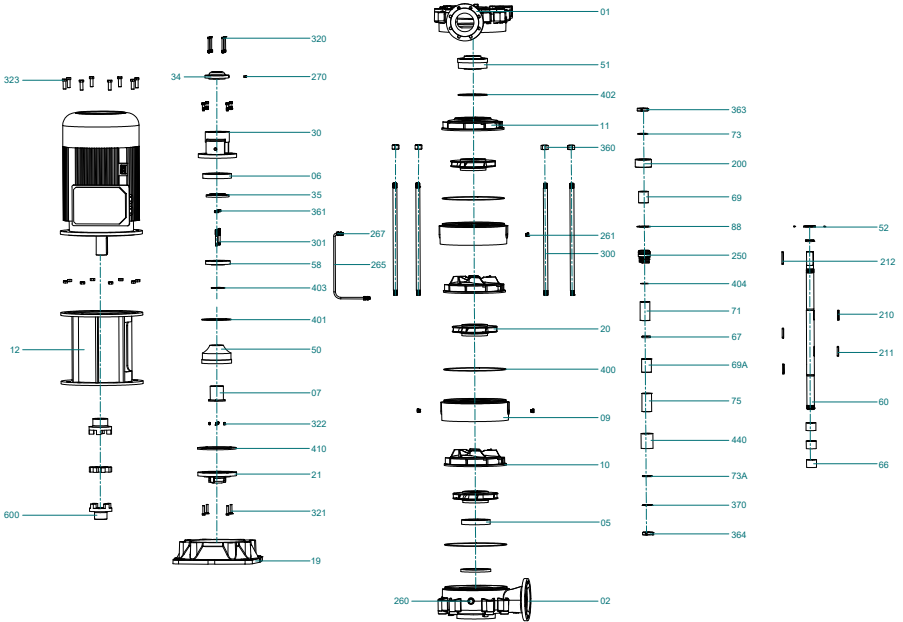



Part No	Part Name	Part No	Part Name	Part No	Part Name
1	Discharge Casing	67	Spacer Bush (Discharge)	301	Puller Stud
2	Suction Casing	69	Clipping Spacer Bushing	320	Hexagon Bolt
7	Wearing Ring	69A	Seal Spacer Bushing	321	Hexagon Bolt
9	Stage (Without Diffuser)	71	Seal Bushing	322	Hexagon Bolt
10	Diffuser	73	Bear Spacer Bushing	323	Hexagon Bolt
11	Last Stage Diffuser	73A	Spacer Washer	360	Gland Nut
12	Adaptor	75	Carbon Sleeve Bushing	361	Nut
19	Base Plate	88	V-Ring	362	Nut
20	Impeller	200	Bearing	363	Safety Nut (Right)
21	Bottom Cover	210	Impeller Key	364	Safety Nut (Left)
30	Bearing Housing	211	Impeller Key	370	Safety Sheet
34	Bearing Cover (Inner)	212	Coupling Key	400	O-Ring
35	Bearing Cover (Outer)	250	Mechanical Seal	401	O-Ring
50	Stuffing Box (Discharge)	260	Plug	402	O-Ring
51	Stuffing Box (Suction)	261	Plug	403	O-Ring
52	Mechanical Seal Sleeve	265	Irrigation Pipe	404	O-Ring
58	Mechanical Seal Cover	267	Angle Union	405	O-Ring
60	Pump Shaft	270	Greaser	440	Carbon Sleeve
66	Shaft Nut	300	Gland Stud	600	Coupling





16.12. KMEV Exploded View and Part List with Soft Packing Design

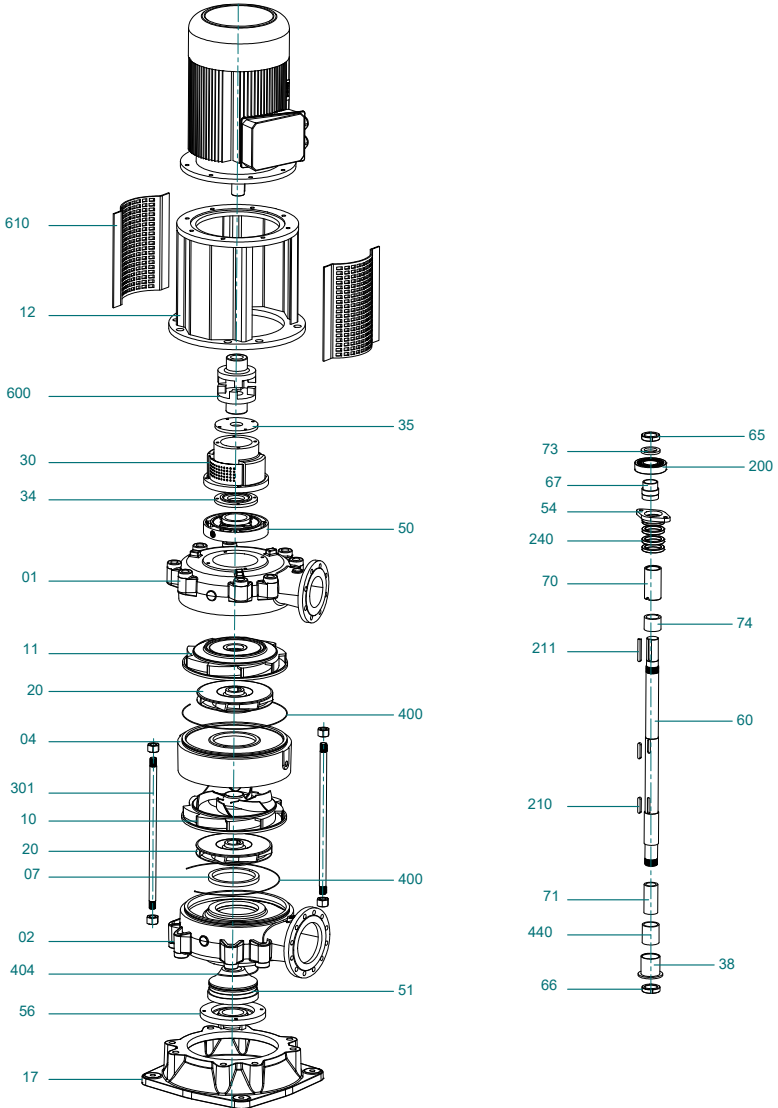



Part No	Part Name	Part No	Part Name	Part No	Part Name
1	Discharge Casing	65	Shaft Nut (Discharge)	300	Gland Stud
2	Suction Casing	66	Shaft Nut	301	Puller Stud
4	Stage (Without Diffuser)	67	Spacer Bush (Discharge)	320	Hexagon Bolt
7	Wear Ring	68	Spacer Bush (Suction)	321	Hexagon Bolt
10	Diffuser	69	Clipping Spacer Bush	322	Hexagon Bolt
11	Last Stage Diffuser	70	Seal Bushing	340	Countersunk Bolt
12	Adaptor	71	Carbon Bear Bushing	341	Countersunk Bolt
17	Base Plate	72	Bear Spacer Bushing (Suction)	342	Set Screw
20	Impeller	73	Bear Spacer Bushing (Discharge)	360	Gland Nut
30	Bearing Housing	74	Impeller Spacer Bushing	361	Nut
34	Bearing Cover (Inner)	88	V-Ring	362	Nut
35	Bearing Cover (Outer)	200	Bearing	400	O-Ring
38	Carbon Sleeve Bushing	210	Impeller Key	401	O-Ring
50	Stuffing Box (Discharge)	211	Impeller Key	402	O-Ring
51	Stuffing Box (Suction)	240	Soft Packing	403	O-Ring
54	Gland	260	Plug	404	O-Ring
56	Bottom Cover	266	Irrigation Pipe	440	Carbon Sleeve
57	Water Ring (Discharge)	267	Angle Union	600	Coupling
60	Pump Shaft	270	Greaser		





NOTES

A series of horizontal dashed lines for writing notes.





NOTES

A series of horizontal dashed lines for writing notes, spanning the width of the page.



masdaf.com



Call Center:

0850 888 8 627 (MAS)

Orta Mahallesi Atayolu Caddesi
No:16 Tuzla - İstanbul / Türkiye



masdaf.com